



Council of the
European Union

Brussels, 21 December 2016
(OR. en)

15755/16
ADD 2

ENT 238
MI 809
ENV 821
DELECT 259

COVER NOTE

From: Secretary-General of the European Commission,
signed by Mr Jordi AYET PUIGARNAU, Director

date of receipt: 19 December 2016

To: Mr Jeppe TRANHOLM-MIKKELSEN, Secretary-General of the Council of
the European Union

No. Cion doc.: C(2016) 8381 final ANNEX 6

Subject: ANNEX to the Commission Delegated Regulation (EU) .../... supplementing
Regulation (EU) 2016/XXX of the European Parliament and of the Council
with regard to technical and general requirements relating to emission
limits and type-approval for internal combustion engines for non-road
mobile machinery

Delegations will find attached document C(2016) 8381 final ANNEX 6.

Encl.: C(2016) 8381 final ANNEX 6



Brussels, 19.12.2016
C(2016) 8381 final

ANNEX 6

ANNEX

to the

Commission Delegated Regulation (EU) .../...

supplementing Regulation (EU) 2016/XXX of the European Parliament and of the Council with regard to technical and general requirements relating to emission limits and type-approval for internal combustion engines for non-road mobile machinery

ANNEX VI

Conduct of emission tests and requirements for measurement equipment

1. Introduction

This Annex describes the method of determining emissions of gaseous and particulate pollutants from the engine to be tested and the specifications related to the measurement equipment. As from section 6., the numbering of this Annex is consistent with the numbering of the NRMM gtr 11 and UN R 96-03, Annex 4B. However, some points of the NRMM gtr 11 are not needed in this Annex, or are modified in accordance with the technical progress.

2. General overview

This Annex contains the following technical provisions needed for conducting an emissions test. Additional provisions are listed in point 3..

- Section 5.: Performance requirements, including the determination of tests speeds
- Section 6.: Test conditions, including the method for accounting for emissions of crankcase gases, the method for determining and accounting for continuous and infrequent regeneration of exhaust after-treatment systems
- Section 7.: Test procedures, including the mapping of engines, the test cycle generation and the test cycle running procedure
- Section 8.: Measurement procedures, including the instrument calibration and performance checks and the instrument validation for the test
- Section 9.: Measurement equipment, including the measurement instruments, the dilution procedures, the sampling procedures and the analytical gases and mass standards
- Appendix 1: PN measurement procedure

3. Related annexes

- Data evaluation and calculation: Annex VII
- Test procedures for dual-fuel engines: Annex VIII
- Reference fuels: Annex IX
- Test cycles: Annex XVII

4. General requirements

The engines to be tested shall meet the performance requirements set out in section 5. when tested in accordance with the test conditions set out in section 6. and the test procedures set out in section 7..

5. Performance requirements

5.1. Emissions of gaseous and particulate pollutants and of CO₂ and NH₃

The pollutants are represented by:

- (a) Oxides of nitrogen, NO_x;
- (b) Hydrocarbons, expressed as total hydrocarbons, HC or THC;
- (c) Carbon monoxide, CO;
- (d) Particulate matter, PM;
- (e) Particle number, PN.

The measured values of gaseous and particulate pollutants and of CO₂ exhausted by the engine refer to the brake-specific emissions in grams per kilowatt-hour (g/kWh).

The gaseous and particulate pollutants that shall be measured are those for which limit values are applicable to the engine sub-category being tested as set out in Annex II to Regulation (EU) 2016/1628. The results, inclusive of the deterioration factor determined according to Annex III, shall not exceed the applicable limit values.

The CO₂ shall be measured and reported for all engine sub-categories as required by Article 41(4) of Regulation (EU) 2016/1628.

The mean emission of ammonia (NH₃) shall additionally be measured, as required in accordance with section 3. of Annex IV, when the NO_x control measures that are part of the engine emission control system include use of a reagent, and shall not exceed the values set out in that section.

The emissions shall be determined on the duty cycles (steady-state and/or transient test cycles), as described in section 7. and in Annex XVII. The measurement systems shall meet the calibration and performance checks set out in section 8. with the measurement equipment described in section 9..

Other systems or analysers may be approved by the approval authority if it is found that they yield equivalent results in accordance with point 5.1.1.. The results shall be calculated according to the requirements of Annex VII.

5.1.1. Equivalency

The determination of system equivalency shall be based on a seven-sample pair (or larger) correlation study between the system under consideration and one of the systems of this annex. "Results" refer to the specific cycle weighted emissions value. The correlation testing is to be performed at the same laboratory, test cell, and on the same engine, and is preferred to be run concurrently. The equivalency of the sample pair averages shall be determined by F-test and t-test statistics as described in Appendix 3 of Annex VII, obtained under the laboratory test cell and the engine conditions described above. Outliers shall be determined in accordance with ISO 5725 and excluded from the database. The systems to be used for correlation testing shall be subject to the approval by the approval authority.

5.2. General requirements on the test cycles

5.2.1. The EU type-approval test shall be conducted using the appropriate NRSC and, where applicable, NRTC or LSI-NRTC, as specified in Article 23 and Annex IV to Regulation (EU) 2016/1628.

5.2.2. The technical specifications and characteristics of the NRSC are set out in Annex XVII, Appendix 1 (discrete-mode NRSC) and Appendix 2 (ramped-modal NRSC). At the choice of the manufacturer, a NRSC test may be run as a discrete-mode NRSC or, where available, as a ramped-modal NRSC ("RMC") as set out in point 7.4.1..

5.2.3. The technical specifications and characteristics of the NRTC and LSI-NRTC are set out in Appendix 3 of Annex XVII.

5.2.4. The test cycles specified in point 7.4. and in Annex XVII are designed around percentages of maximum torque or power and test speeds that need to be determined for the correct performance of the test cycles:

- (a) 100 % speed (maximum test speed (MTS) or rated speed)
- (b) Intermediate speed(s) as specified in point 5.2.5.4;
- (c) Idle speed, as specified in point 5.2.5.5..

The determination of the test speeds is set out in point 5.2.5., the use of torque and power in point 5.2.6..

5.2.5. Test speeds

5.2.5.1. Maximum test speed (MTS)

The MTS shall be calculated in accordance with point 5.2.5.1.1. or point 5.2.5.1.3..

5.2.5.1.1. Calculation of MTS

In order to calculate the MTS the transient mapping procedure shall be performed in accordance with point 7.4.. The MTS is then determined from the mapped values of

engine speed versus power. MTS shall be calculated by means of equation (6-1), (6-2) or (6-3):

$$(a) \quad MTS = n_{lo} + 0,95 \cdot (n_{hi} - n_{lo}) \quad (6-1)$$

$$(b) \quad MTS = n_i \quad (6-2)$$

with:

n_i is the average of the lowest and highest speeds at which $(n_{normi}^2 + P_{normi}^2)$ is equal to 98 % of the maximum value of $(n_{normi}^2 + P_{normi}^2)$

(c) If there is only one speed at which the value of $(n_{normi}^2 + P_{normi}^2)$ is equal to 98% of the maximum value of $(n_{normi}^2 + P_{normi}^2)$:

$$MTS = n_i \quad (6-3)$$

with:

n_i is the speed at which the maximum value of $(n_{normi}^2 + P_{normi}^2)$ occurs.

where:

$n =$ is the engine speed

$i =$ is an indexing variable that represents one recorded value of an engine map

$n_{hi} =$ is the high speed as defined in Article 2(12),

$n_{lo} =$ is the low speed as defined in Article 2(13),

$n_{normi} =$ is an engine speed normalized by dividing it by n_{Pmax}

$P_{normi} =$ is an engine power normalized by dividing it by P_{max}

n_{Pmax} is the average of the lowest and highest speeds at which power is equal to 98 % of P_{max} .

Linear interpolation shall be used between the mapped values to determine:

(a) the speeds where power is equal to 98 % of P_{max} . If there is only one speed at which power is equal to 98% of P_{max} , n_{Pmax} shall be the speed at which P_{max} occurs;

(b) the speeds where $(n_{normi}^2 + P_{normi}^2)$ is equal to 98 % of the maximum value of $(n_{normi}^2 + P_{normi}^2)$.

(a) Use of a declared MTS

If the MTS calculated in accordance with point 5.2.5.1.1. or 5.2.5.1.3. is within $\pm 3\%$ of the MTS declared by the manufacturer, the declared MTS may be used for the emissions test. If the tolerance is exceeded, the measured MTS shall be used for the emissions test.

(b) Use of an adjusted MTS

If the falling part of the full load curve has a very steep edge, this may cause problems to drive the 105 % speeds of the NRTC correctly. In this case it is allowed, with prior agreement of the technical service, to use an alternative value of MTS determined using one of the following methods:

- (a) the MTS may be slightly reduced (maximum 3 %) in order to make correct driving of the NRTC possible.
- (b) Calculate an alternative MTS by means of equation (6-4):

$$MTS = ((n_{\max} - n_{\text{idle}})/1.05) + n_{\text{idle}} \quad (6-4)$$

where:

n_{\max} = is the engine speed at which the engine governor function controls engine speed with operator demand at maximum and with zero load applied ("maximum no-load speed")

n_{idle} = is the idle speed

5.2.5.2. Rated speed

The rated speed is defined in Article 3(29) of Regulation (EU) 2016/1628. Rated speed for variable-speed engines subject to an emission test shall be determined from the applicable mapping procedure set out in section 7.6.. Rated speed for constant-speed engines shall be declared by the manufacturer according to the characteristics of the governor. Where an engine type equipped with alternative speeds as permitted by Article 3(21) of Regulation (EU) 2016/1628 is subject to an emission test, each alternative speed shall be declared and tested.

If the rated speed determined from the mapping procedure in section 7.6. is within ± 150 rpm of the value declared by the manufacturer for engines of category NRS provided with governor, or within ± 350 rpm or $\pm 4\%$ for engines of category NRS without governor, whichever is smaller, or within ± 100 rpm for all other engine categories, the declared value may be used. If the tolerance is exceeded, the rated speed determined from the mapping procedure shall be used.

For engines of category NRSh the 100 % test speed shall be within ± 350 rpm of the rated speed.

Optionally, MTS may be used instead of rated speed for any steady state test cycle.

5.2.5.3. Maximum torque speed for variable-speed engines

The maximum torque speed determined from the maximum torque curve established from the applicable engine mapping procedure in point 7.6.1 or 7.6.2. shall be one of the following:

- (a) The speed at which the highest torque was recorded; or,
- (b) The average of the lowest and highest speeds at which the torque is equal to 98 % of the maximum torque. Where necessary, linear interpolation shall be used to determine the speeds at which the torque is equal to 98 % of the maximum torque.

If the maximum torque speed determined from the maximum torque curve is within ± 4 % of the maximum torque speed declared by the manufacturer for engines of category NRS or NRSh, or $\pm 2,5$ % of the maximum torque speed declared by the manufacturer for all other engine categories, the declared value may be used for the purpose of this regulation. If the tolerance is exceeded, the maximum torque speed determined from the maximum torque curve shall be used.

5.2.5.4. Intermediate speed

The intermediate speed shall meet one of the following requirements:

- (a) For engines that are designed to operate over a speed range on a full load torque curve, the intermediate speed shall be the maximum torque speed if it occurs between 60 % and 75 % of rated speed;
- (b) If the maximum torque speed is less than 60 % of rated speed, then the intermediate speed shall be 60 % of the rated speed;
- (c) If the maximum torque speed is greater than 75 % of the rated speed then the intermediate speed shall be 75 % of rated speed. Where the engine is only capable of operation at speeds higher than 75% of rated speed the intermediate speed shall be the lowest speed at which the engine can be operated;
- (d) For engines that are not designed to operate over a speed range on a full-load torque curve at steady-state conditions, the intermediate speed shall be between 60 % and 70 % of the rated speed.
- (e) For engines to be tested on cycle G1, except for engines of category ATS, the intermediate speed shall be 85 % of the rated speed.
- (f) For engines of category ATS tested on cycle G1 the intermediate speed shall be 60% or 85% of rated speed based on which is closer to the actual maximum torque speed.

Where the MTS is used in place of rated speed for the 100% test speed, MTS shall also replace rated speed when determining the intermediate speed.

5.2.5.5. Idle speed

The idle speed is the lowest engine speed with minimum load (greater than or equal to zero load), where an engine governor function controls engine speed. For engines without a governor function that controls idle speed, idle speed means the manufacturer-declared value for lowest engine speed possible with minimum load. Note that warm idle speed is the idle speed of a warmed-up engine.

5.2.5.6. Test speed for constant-speed engines

The governors of constant-speed engines may not always maintain speed exactly constant. Typically speed can decrease (0,1 to 10) % below the speed at zero load, such that the minimum speed occurs near the engine's point of maximum power. The test speed for constant-speed engines may be commanded by using the governor installed on the engine or using a test-bed speed demand where this represents the engine governor.

Where the governor installed on the engine is used the 100 % speed shall be the engine governed speed as defined in Article 2(24).

Where a test-bed speed demand signal is used to simulate the governor, the 100% speed at zero load shall be the no-load speed specified by the manufacturer for that governor setting and the 100% speed at full load shall be the rated speed for that governor setting. Interpolation shall be used to determine the speed for the other test modes.

Where the governor has an isochronous operation setting, or the rated speed and no-load speed declared by the manufacturer differ by no more than 3 %, a single value declared by the manufacturer may be used for the 100 % speed at all load points.

5.2.6. Torque and Power

5.2.6.1. Torque

The torque figures given in the test cycles are percentage values that represent, for a given test mode, one of the following:

- (a) The ratio of the required torque to the maximum possible torque at the specified test speed (all cycles except D2 & E2);
- (b) The ratio of the required torque to the torque corresponding to the rated net power declared by the manufacturer (cycle D2 & E2).

5.2.6.2. Power

The power figures given in the test cycles are percentage values that represent, for a given test mode, one of the following:

- (a) For the test cycle E3 the power figures are percentage values of the maximum net power at the 100 % speed as this cycle is based on a theoretical propeller

characteristic curve for vessels driven by heavy-duty engines without limitation of length.

- (b) For the test cycle F the power figures are percentage values of the maximum net power at the given test speed, except for idle speed where it is a percentage of the maximum net power at the 100 % speed.

6. Test Conditions

6.1. Laboratory test conditions

The absolute temperature (T_a) of the engine air at the inlet to the engine expressed in Kelvin, and the dry atmospheric pressure (p_s), expressed in kPa shall be measured and the parameter f_a shall be determined in accordance with the following provisions and by means of equation (6-5) or (6-6). If the atmospheric pressure is measured in a duct, negligible pressure losses shall be ensured between the atmosphere and the measurement location, and changes in the duct's static pressure resulting from the flow shall be accounted for. In multi-cylinder engines having distinct groups of intake manifolds, such as in a "V" engine configuration, the average temperature of the distinct groups shall be taken. The parameter f_a shall be reported with the test results.

Naturally aspirated and mechanically supercharged engines:

$$f_a = \left(\frac{99}{p_s} \right) \times \left(\frac{T_a}{298} \right)^{0.7} \quad (6-5)$$

Turbocharged engines with or without cooling of the intake air:

$$f_a = \left(\frac{99}{p_s} \right)^{0.7} \times \left(\frac{T_a}{298} \right)^{1.5} \quad (6-6)$$

6.1.1. For the test to be considered valid both the following conditions must be met:

- (a) f_a shall be within the range $0,93 \leq f_a \leq 1,07$ except as permitted by points 6.1.2. and 6.1.4.;
- (b) The temperature of intake air shall be maintained to 298 ± 5 K ($25 \pm 5^\circ\text{C}$), measured upstream of any engine component, except as permitted by points 6.1.3. and 6.1.4., and as required by points 6.1.5. and 6.1.6..

6.1.2. Where the altitude of the laboratory in which the engine is being tested exceeds 600 m, with the agreement of the manufacturer f_a may exceed 1,07 on the condition that p_s shall not be less than 80 kPa.

- 6.1.3. Where the power of the engine being tested is greater than 560 kW, with the agreement of the manufacturer the maximum value of intake air temperature may exceed 303 K (30°C) on the condition that it shall not exceed 308 K (35°C).
- 6.1.4. Where the altitude of the laboratory in which the engine is being tested exceeds 300 m and the power of the engine being tested is greater than 560 kW, with the agreement of the manufacturer f_a may exceed 1,07 on the condition that p_s shall not be less than 80 kPa and the maximum value of intake air temperature may exceed 303 K (30°C) on the condition that it shall not exceed 308 K (35°C).
- 6.1.5. In the case of an engine family of category NRS less than 19 kW exclusively consisting of engine types to be used in snow throwers, the temperature of the intake air shall be maintained between 273 K and 268 K (0 °C and -5 °C).
- 6.1.6. For engines of category SMB the temperature of the intake air shall be maintained to 263 ± 5 K (-10 ± 5 °C), except as permitted by point 6.1.6.1..
- 6.1.6.1. For engines of category SMB fitted with electronically controlled fuel injection that adjusts the fuel flow to the intake air temperature, at the choice of the manufacturer the temperature of the intake air may alternatively be maintained to 298 ± 5 K (25 ± 5 °C).
- 6.1.7. It is allowed to use:
- (a) an atmospheric pressure meter whose output is used as the atmospheric pressure for an entire test facility that has more than one dynamometer test cell, as long as the equipment for handling intake air maintains ambient pressure, where the engine is tested, within ± 1 kPa of the shared atmospheric pressure;
 - (b) A humidity measurement device to measure the humidity of intake air for an entire test facility that has more than one dynamometer test cell, as long as the equipment for handling intake air maintains dew point, where the engine is tested, within $\pm 0,5$ K of the shared humidity measurement.
- 6.2. Engines with charge air cooling
- (a) A charge-air cooling system with a total intake-air capacity that represents production engines' in-use installation shall be used. Any laboratory charge-air cooling system to minimize accumulation of condensate shall be designed. Any accumulated condensate shall be drained and all drains shall be completely closed before emission testing. The drains shall be kept closed during the emission test. Coolant conditions shall be maintained as follows:
 - (a) a coolant temperature of at least 20 °C shall be maintained at the inlet to the charge-air cooler throughout testing;
 - (b) at the rated speed and full load, the coolant flow rate shall be set to achieve an air temperature within ± 5 °C of the value designed by the manufacturer after the charge-air cooler's outlet. The air-outlet temperature shall be

measured at the location specified by the manufacturer. This coolant flow rate set point shall be used throughout testing;

- (c) if the engine manufacturer specifies pressure-drop limits across the charge-air cooling system, it shall be ensured that the pressure drop across the charge-air cooling system at engine conditions specified by the manufacturer is within the manufacturer's specified limit(s). The pressure drop shall be measured at the manufacturer's specified locations;

When the MTS defined in point 5.2.5.1. is being used in place of rated speed to run the test cycle then this speed may be used in place of rated speed when setting the charge air temperature.

The objective is to produce emission results that are representative of in-use operation. If good engineering judgment indicates that the specifications in this section would result in unrepresentative testing (such as overcooling of the intake air), more sophisticated set points and controls of charge-air pressure drop, coolant temperature, and flow rate may be used to achieve more representative results.

6.3. Engine power

6.3.1. Basis for emission measurement

The basis of specific emissions measurement is uncorrected net power as defined in Article 3(23) of Regulation (EU) 2016/1628.

6.3.2. Auxiliaries to be fitted

During the test, the auxiliaries necessary for the engine operation shall be installed on the test bench according to the requirements of Appendix 2.

Where the necessary auxiliaries cannot be fitted for the test, the power they absorb shall be determined and subtracted from the measured engine power.

6.3.3. Auxiliaries to be removed

Certain auxiliaries whose definition is linked with the operation of the non-road mobile machinery and which may be mounted on the engine shall be removed for the test.

Where auxiliaries cannot be removed, the power they absorb in the unloaded condition may be determined and added to the measured engine power (see note g in Appendix 2). If this value is greater than 3 % of the maximum power at the test speed it may be verified by the technical service. The power absorbed by auxiliaries shall be used to adjust the set values and to calculate the work produced by the engine over the test cycle in accordance with point 7.7.1.3. or point 7.7.2.3.1..

6.3.4. Determination of auxiliary power

The power absorbed by the auxiliaries/equipment needs only be determined, if:

- (a) Auxiliaries/equipment required according to Appendix 2, are not fitted to the engine;
- and/or
- (b) Auxiliaries/equipment not required according to Appendix 2, are fitted to the engine.

The values of auxiliary power and the measurement/calculation method for determining auxiliary power shall be submitted by the engine manufacturer for the whole operating area of the applicable test cycles, and approved by the approval authority.

6.3.5. Engine cycle work

The calculation of reference and actual cycle work (see point 7.8.3.4.) shall be based upon engine power in accordance with point 6.3.1. In this case, P_f and P_r of equation (6-7) are zero, and P equals P_m .

If auxiliaries/equipment are installed in accordance with points 6.3.2. and/or 6.3.3., the power absorbed by them shall be used to correct each instantaneous cycle power value $P_{m,i}$, by means of equation (6-8):

$$P_i = P_{m,i} - P_{f,i} + P_{r,i} \quad (6-7)$$

$$P_{AUX} = P_{r,i} - P_{f,i} \quad (6-8)$$

Where:

- $P_{m,i}$ is the measured engine power, kW
- $P_{f,i}$ is the power absorbed by auxiliaries/equipment to be fitted for the test but that were not installed, kW
- $P_{r,i}$ is the power absorbed by auxiliaries/equipment to be removed for the test but that were installed, kW.

6.4. Engine intake air

6.4.1. Introduction

The intake-air system installed on the engine or one that represents a typical in-use configuration shall be used. This includes the charge-air cooling and exhaust gas recirculation (EGR).

6.4.2. Intake air pressure restriction

An engine air intake system or a test laboratory system shall be used presenting an air intake pressure restriction within ± 300 Pa of the maximum value specified by the

manufacturer for a clean air cleaner at the rated speed and full load. Where this is not possible due to the design of the test laboratory air supply system a pressure restriction not exceeding the value specified by the manufacturer for a dirty filter shall be permitted subject to prior approval of the technical service. The static differential pressure of the pressure restriction shall be measured at the location and at the speed and torque set points specified by the manufacturer. If the manufacturer does not specify a location, this pressure shall be measured upstream of any turbocharger or exhaust gas recirculation (EGR) connection to the intake air system.

When the MTS defined in point 5.2.5.1. is being used in place of rated speed to run the test cycle then this speed may be used in place of rated speed when setting the intake air pressure restriction.

6.5. Engine exhaust system

The exhaust system installed with the engine or one that represents a typical in-use configuration shall be used. The exhaust system shall conform to the requirements for exhaust emissions sampling, as set out in point 9.3.. An engine exhaust system or a test laboratory system shall be used presenting a static exhaust gas back-pressure within 80 to 100 % of the maximum exhaust gas pressure restriction at the rated speed and full load. The exhaust gas pressure restriction may be set using a valve. If the maximum exhaust gas pressure restriction is 5 kPa or less, the set point shall not be more than 1,0 kPa from the maximum. When the MTS defined in point 5.2.5.1. is being used in place of rated speed to run the test cycle then this speed may be used in place of rated speed when setting the exhaust gas pressure restriction.

6.6. Engine with exhaust after-treatment system

If the engine is equipped with an exhaust after-treatment system that is not mounted directly on the engine, the exhaust pipe shall have the same diameter as found in-use for at least four pipe diameters upstream of the expansion section containing the after-treatment device. The distance from the exhaust manifold flange or turbocharger outlet to the exhaust after-treatment system shall be the same as in the non-road mobile machinery configuration or within the distance specifications of the manufacturer. Where specified by the manufacturer the pipe shall be insulated to achieve an after-treatment inlet temperature within the specification of the manufacturer. Where other installation requirements are specified by the manufacturer these shall also be respected for the test configuration. The exhaust gas back-pressure or pressure restriction shall be set according to point 6.5.. For exhaust after-treatment devices with variable exhaust gas pressure restriction, the maximum exhaust gas pressure restriction used in point 6.5. is defined at the after-treatment condition (degreening/ageing and regeneration/loading level) specified by the manufacturer. The after-treatment container may be removed during dummy tests and during engine mapping, and replaced with an equivalent container having an inactive catalyst support.

The emissions measured on the test cycle shall be representative of the emissions in the field. In the case of an engine equipped with an exhaust after-treatment system that

requires the consumption of a reagent, the reagent used for all tests shall be declared by the manufacturer.

For engines of category NRE, NRG, IWP, IWA, RLR, NRS, NRSh, SMB, and ATS equipped with exhaust after-treatment systems that are regenerated on an infrequent (periodic) basis, as described in point 6.6.2., emission results shall be adjusted to account for regeneration events. In this case, the average emission depends on the frequency of the regeneration event in terms of fraction of tests during which the regeneration occurs. After-treatment systems with a regeneration process that occurs either in a sustained manner or at least once over the applicable transient (NRTC or LSI-NRTC) test cycle or RMC ("continuous regeneration") in accordance with point 6.6.1. do not require a special test procedure.

6.6.1. Continuous regeneration

For an exhaust after-treatment system based on a continuous regeneration process the emissions shall be measured on an after-treatment system that has been stabilized so as to result in repeatable emissions behaviour. The regeneration process shall occur at least once during the hot-start NRTC, LSI-NRTC or NRSC test, and the manufacturer shall declare the normal conditions under which regeneration occurs (soot load, temperature, exhaust gas back-pressure, etc.). In order to demonstrate that the regeneration process is continuous, at least three hot-start runs of the NRTC, LSI-NRTC or NRSC shall be conducted. In case of hot-start NRTC, the engine shall be warmed up in accordance with point 7.8.2.1., the engine be soaked according to point 7.4.2.1.(b) and the first hot-start NRTC.

The subsequent hot-start NRTC shall be started after soaking according with point 7.4.2.1.(b). During the tests, exhaust gas temperatures and pressures shall be recorded (temperature before and after the exhaust after-treatment system, exhaust gas back-pressure, etc.). The exhaust after-treatment system is considered to be satisfactory if the conditions declared by the manufacturer occur during the test within a sufficient time and the emission results do not scatter by more than $\pm 25\%$ from the mean value or 0,005 g/kWh, whichever is greater.

6.6.2. Infrequent regeneration

This provision only applies to engines equipped with an exhaust after-treatment system that is regenerated on an infrequent basis, typically occurring in less than 100 hours of normal engine operation. For those engines, either additive or multiplicative factors shall be determined for upward and downward adjustment as referred to in point 6.6.2.4. ("adjustment factor").

Testing and development of adjustment factors is only required for one applicable transient (NRTC or LSI-NRTC) test cycle or RMC. The factors that have been developed may be applied to results from the other applicable test cycles including discrete-mode NRSC.

In case that no suitable adjustment factors are available from testing using transient (NRTC or LSI-NRTC) test cycle or RMC then adjustment factors shall be established using an applicable discrete-mode NRSC test. Factors developed using a discrete-mode NRSC test shall only be applied to discrete-mode NRSC.

It shall not be required to conduct testing and develop adjustment factors on both RMC and discrete-mode NRSC.

6.6.2.1. Requirement for establishing adjustment factors using NRTC, LSI-NRTC or RMC

The emissions shall be measured on at least three hot-start runs of the NRTC, LSI-NRTC or RMC, one with and two without a regeneration event on a stabilized exhaust after-treatment system. The regeneration process shall occur at least once during the NRTC, LSI-NRTC or RMC with a regeneration event. If regeneration takes longer than one NRTC, LSI-NRTC or RMC, consecutive NRTC, LSI-NRTC or RMC shall be run and emissions continued to be measured without shutting the engine off until regeneration is completed and the average of the tests shall be calculated. If regeneration is completed during any test, the test shall be continued over its entire length.

An appropriate adjustment factor shall be determined for the entire applicable cycle by means of equations (6-10) to (6-13).

6.6.2.2. Requirement for establishing adjustment factors using discrete-mode NRSC testing

Starting with a stabilized exhaust after-treatment system the emissions shall be measured on at least three runs of each test mode of the applicable discrete-mode NRSC on which the conditions for regeneration can be met, one with and two without a regeneration event. The measurement of PM shall be conducted using the multiple filter method described in point 7.8.1.2.(c). If regeneration has started but is not complete at the end of the sampling period for a specific test mode extend the sampling period shall be extended until regeneration is complete. Where there are multiple runs for the same mode an average result shall be calculated. The process shall be repeated for each test mode.

An appropriate adjustment factor shall be determined by means of equations (6-10) to (6-13) for those modes of the applicable cycle for which regeneration occurs.

6.6.2.3. General procedure for developing infrequent regeneration adjustment factors (IRAFs)

The manufacturer shall declare the normal parameter conditions under which the regeneration process occurs (soot load, temperature, exhaust gas back-pressure, etc.). The manufacturer shall also provide the frequency of the regeneration event in terms of number of tests during which the regeneration occurs. The exact procedure to determine this frequency shall be agreed by the type approval or certification authority based upon good engineering judgement.

For a regeneration test, the manufacturer shall provide an exhaust after-treatment system that has been loaded. Regeneration shall not occur during this engine conditioning phase. As an option, the manufacturer may run consecutive tests of the applicable cycle until the exhaust after-treatment system is loaded. Emissions measurement is not required on all tests.

Average emissions between regeneration phases shall be determined from the arithmetic mean of several approximately equidistant tests of the applicable cycle. As a minimum, at least one applicable cycle as close as possible prior to a regeneration test and one applicable cycle immediately after a regeneration test shall be conducted.

During the regeneration test, all the data needed to detect regeneration shall be recorded (CO or NO_x emissions, temperature before and after the exhaust after-treatment system, exhaust gas back-pressure, etc.). During the regeneration process, the applicable emission limits may be exceeded. The test procedure is schematically shown in Figure 6.1..

Figure 6.1.

Scheme of infrequent (periodic) regeneration with n number of measurements and n_r number of measurements during regeneration.

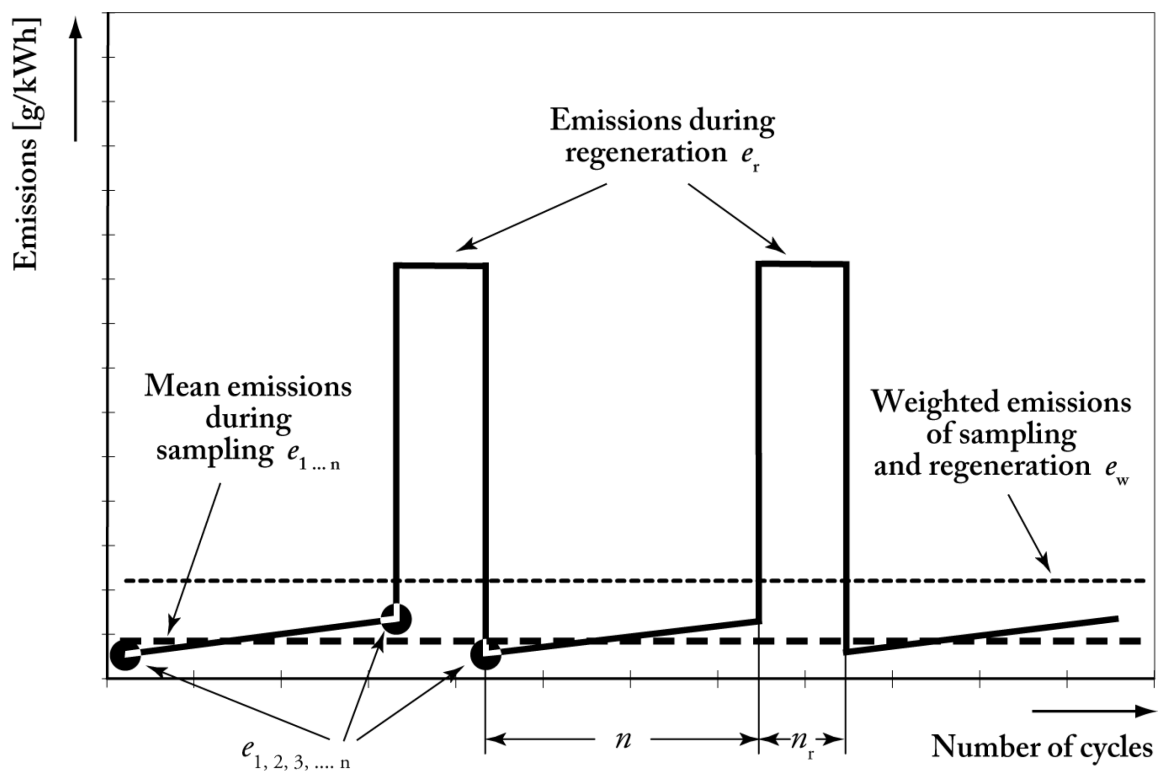

The average specific emission rate related to the test runs conducted according to points 6.6.2.1. or 6.6.2.2. [g/kWh or #/kWh] shall be weighted by means of equation (6-9) (see Figure 6.1.):

$$\bar{e}_w = \frac{n \cdot \bar{e} + n_r \cdot \bar{e}_r}{n + n_r} \quad (6-9)$$

Where:

n is the number of tests in which regeneration does not occur,

n_r is the number of tests in which regeneration occurs (minimum one test),

\bar{e} is the average specific emission from a test in which the regeneration does not occur [g/kWh or #/kWh]

\bar{e}_r is the average specific emission from a test in which the regeneration occurs [g/kWh or #/kWh]

At the choice of the manufacturer and based on upon good engineering judgment, the regeneration adjustment factor k_r , expressing the average emission rate, may be calculated either multiplicative or additive for all gaseous pollutants, and, where there is an applicable limit, for PM and PN, by means of equations (6-10) to (6-13):

Multiplicative

$$k_{ru,m} = \frac{e_w}{e} \quad (\text{upward adjustment factor}) \quad (6-10)$$

$$k_{rd,m} = \frac{e_w}{e_r} \quad (\text{downward adjustment factor}) \quad (6-11)$$

Additive

$$k_{ru,a} = e_w - e \quad (\text{upward adjustment factor}) \quad (6-12)$$

$$k_{rd,a} = e_w - e_r \quad (\text{downward adjustment factor}) \quad (6-13)$$

6.6.2.4. Application of adjustment factors

Upward adjustment factors are multiplied with or added to measured emission rates for all tests in which the regeneration does not occur. Downward adjustment factors are

multiplied with or added to measured emission rates for all tests in which the regeneration occurs. The occurrence of the regeneration shall be identified in a manner that is readily apparent during all testing. Where no regeneration is identified, the upward adjustment factor shall be applied.

With reference to Annex VII and Appendix 5 of Annex VII on brake specific emission calculations, the regeneration adjustment factor:

- (a) When established for an entire weighted cycle, shall be applied to the results of the applicable weighted NRTC, LSI-NRTC and NRSC;
- (b) When established specifically for the individual modes of the applicable discrete-mode NRSC, shall be applied to the results of those modes of the applicable discrete-mode NRSC for which regeneration occurs prior to calculating the cycle weighted emission result. In this case the multiple filter method shall be used for PM measurement;
- (c) May be extended to other members of the same engine family;
- (d) May be extended to other engine families within the same engine after-treatment system family, as defined in Annex IX to Commission Implementing Regulation 2016/CCC on administrative requirements, with the prior approval of the approval authority based on technical evidence to be supplied by the manufacturer that the emissions are similar.

The following options shall apply:

- (a) A manufacturer may elect to omit adjustment factors for one or more of its engine families (or configurations) because the effect of the regeneration is small, or because it is not practical to identify when regenerations occur. In these cases, no adjustment factor shall be used, and the manufacturer is liable for compliance with the emission limits for all tests, without regard to whether a regeneration occurs;
- (b) Upon request by the manufacturer, the approval authority may account for regeneration events differently than is provided in paragraph (a). However, this option only applies to events that occur extremely infrequently, and which cannot be practically addressed using the adjustment factors described in paragraph (a).

6.7. Cooling system

An engine cooling system with sufficient capacity to maintain the engine, with its intake-air, oil, coolant, block and head temperatures, at normal operating temperatures prescribed by the manufacturer shall be used. Laboratory auxiliary coolers and fans may be used.

6.8. Lubricating oil

The lubricating oil shall be specified by the manufacturer and be representative of lubricating oil available in the market; the specifications of the lubricating oil used for the test shall be recorded and presented with the results of the test.

6.9. Specification of the reference fuel

The reference fuels to be used for the test are specified in Annex IX.

The fuel temperature shall be in accordance with the manufacturer's recommendations. The fuel temperature shall be measured at the inlet to the fuel injection pump or as specified by the manufacturer, and the location of measurement recorded.

6.10. Crankcase emissions

This section shall apply to engines of category NRE, NRG, IWP, IWA, RLR, NRS, NRSh, SMB, & ATS complying with Stage V emission limits set out in Annex II to Regulation (EU) 2016/1628.

Crankcase emissions that are discharged directly into the ambient atmosphere shall be added to the exhaust emissions (either physically or mathematically) during all emission testing.

Manufacturers taking advantage of this exception shall install the engines so that all crankcase emission can be routed into the emissions sampling system. For the purpose of this point, crankcase emissions that are routed into the exhaust gas upstream of exhaust after-treatment system during all operation are not considered to be discharged directly into the ambient atmosphere.

Open crankcase emissions shall be routed into the exhaust system for emission measurement, as follows:

- (a) The tubing materials shall be smooth-walled, electrically conductive, and not reactive with crankcase emissions. Tube lengths shall be minimized as far as possible;
- (b) The number of bends in the laboratory crankcase tubing shall be minimized, and the radius of any unavoidable bend shall be maximized;
- (c) The laboratory crankcase exhaust tubing shall meet the engine manufacturer's specifications for crankcase back-pressure;
- (d) The crankcase exhaust tubing shall connect into the raw exhaust gas downstream of any exhaust after-treatment system, downstream of any installed exhaust emissions restriction, and sufficiently upstream of any sample probes to ensure complete mixing with the engine's exhaust system before sampling. The crankcase exhaust tube shall extend into the free stream of exhaust system to avoid boundary-layer effects and to promote mixing. The crankcase exhaust tube's outlet may orient in any direction relative to the raw exhaust gas flow.

7. Test procedures

7.1. Introduction

This chapter describes the determination of brake specific emissions of gaseous and particulate pollutants on engines to be tested. The test engine shall be the parent engine configuration for the engine family as specified Annex IX to Commission Implementing Regulation 2016/CCC on administrative requirements.

A laboratory emission test consists of measuring emissions and other parameters for the test cycles specified in Annex XVII. The following aspects are treated:

- (a) The laboratory configurations for measuring the emissions (point 7.2.);
- (b) The pre-test and post-test verification procedures (point 7.3.);
- (c) The test cycles (point 7.4.);
- (d) The general test sequence (point 7.5.);
- (e) The engine mapping (point 7.6.);
- (f) The test cycle generation (point 7.7.);
- (g) The specific test cycle running procedure (point. 7.8.).

7.2. Principle of emission measurement

To measure the brake-specific emissions, the engine shall be operated over the test cycles defined in point 7.4., as applicable. The measurement of brake-specific emissions requires the determination of the mass of pollutants in the exhaust emissions (i.e. HC, CO, NO_x and PM), the number of particulates in the exhaust emissions (i.e. PN), the mass of CO₂ in the exhaust emissions, and the corresponding engine work.

7.2.1. Mass of constituent

The total mass of each constituent shall be determined over the applicable test cycle by using the following methods:

7.2.1.1. Continuous sampling

In continuous sampling, the constituent's concentration is measured continuously from raw or diluted exhaust gas. This concentration is multiplied by the continuous (raw or diluted) exhaust gas flow rate at the emission sampling location to determine the constituent's flow rate. The constituent's emission is continuously summed over the test interval. This sum is the total mass of the emitted constituent.

7.2.1.2. Batch sampling

In batch sampling, a sample of raw or diluted exhaust gas is continuously extracted and stored for later measurement. The extracted sample shall be proportional to the raw or diluted exhaust gas flow rate. Examples of batch sampling are collecting diluted gaseous emissions in a bag and collecting PM on a filter. In principle the method of emission calculation is done as follows: the batch sampled concentrations are multiplied by the total mass or mass flow (raw or dilute) from which it was extracted during the test cycle. This product is the total mass or mass flow of the emitted constituent. To calculate the PM concentration, the PM deposited onto a filter from proportionally extracted exhaust gas shall be divided by the amount of filtered exhaust gas.

7.2.1.3. Combined sampling

Any combination of continuous and batch sampling is permitted (e.g. PM with batch sampling and gaseous emissions with continuous sampling).

Figure 6.2. illustrates the two aspects of the test procedures for measuring emissions: the equipment with the sampling lines in raw and diluted exhaust gas and the operations requested to calculate the pollutant emissions in steady-state and transient test cycles.

Figure 6.2.
Test procedures for emission measurement

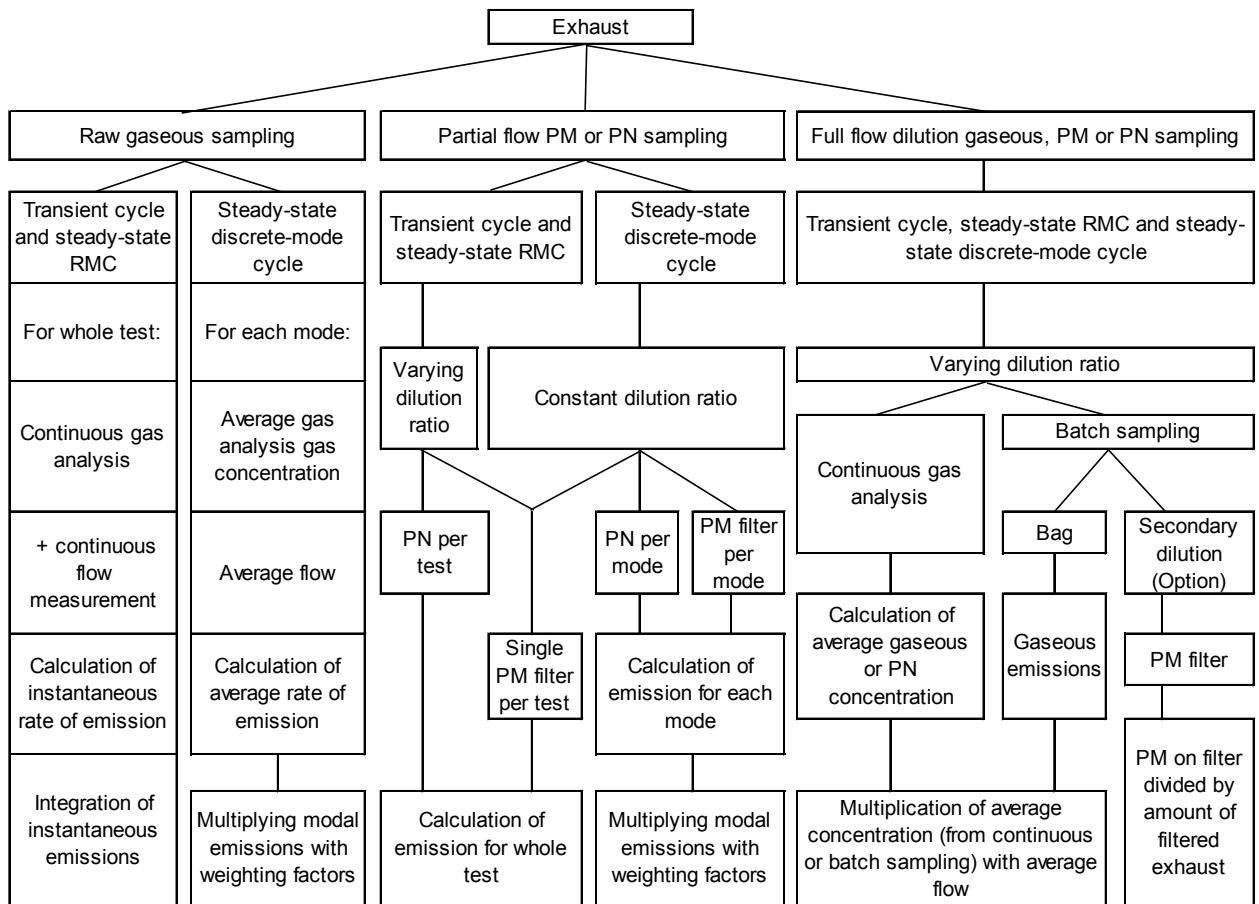

Note on Figure 6.2.: The term "Partial flow PM sampling" includes the partial flow dilution to extract only raw exhaust gas with constant or varying dilution ratio.

7.2.2. Work determination

The work shall be determined over the test cycle by synchronously multiplying speed and brake torque to calculate instantaneous values for engine brake power. Engine brake power shall be integrated over the test cycle to determine total work.

7.3. Verification and calibration

7.3.1. Pre-test procedures

7.3.1.1. Preconditioning

To achieve stable conditions, the sampling system and the engine shall be preconditioned before starting a test sequence as specified in this point.

The intent of engine preconditioning is to achieve the representativeness of emissions and emission controls over the duty cycle and to reduce bias in order to meet stable conditions for the following emission test.

Emissions may be measured during preconditioning cycles, as long as a predefined number of preconditioning cycles are performed and the measurement system has been started according to the requirements of point 7.3.1.4.. The amount of preconditioning shall be identified by the engine manufacturer before starting to precondition. Preconditioning shall be performed as follows, noting that the specific cycles for preconditioning are the same ones that apply for emission testing.

7.3.1.1.1. Preconditioning for cold-start run of NRTC

The engine shall be preconditioned by running at least one hot-start NRTC. Immediately after completing each preconditioning cycle, the engine shall be shut down and the engine-off hot-soak period shall be completed. Immediately after completing the last preconditioning cycle, the engine shall be shut down and the engine cool down described in point 7.3.1.2. shall be started.

7.3.1.1.2. Preconditioning for hot-start run of NRTC or for LSI-NRTC

This point describes the pre-conditioning that shall be applied when it is intended to sample emissions from the hot-start NRTC without running the cold-start run of the NRTC ("cold-start NRTC"), or for the LSI-NRTC. The engine shall be preconditioned by running at least one hot-start NRTC or LSI-NRTC as applicable. Immediately after completing each preconditioning cycle, the engine shall be shut down, and then the next cycle shall be started as soon as practical. It is recommended that the next preconditioning cycle shall be started within 60 seconds after completing the last preconditioning cycle. Where applicable, following the last pre-conditioning cycle the appropriate hot-soak (hot-start NRTC) or cool-down (LSI-NRTC) period shall apply before the engine is started for the emissions test. Where no hot-soak or cool down period applies it is recommended that the emissions test shall be started within 60 seconds after completing the last pre-conditioning cycle.

7.3.1.1.3. Preconditioning for discrete-mode NRSC

For engine categories other than NRS and NRSh the engine shall be warmed-up and run until engine temperatures (cooling water and lube oil) have been stabilized on 50 % speed and 50 % torque for any discrete-mode NRSC test cycle other than type D2, E2, or G, or nominal engine speed and 50 % torque for any discrete-mode NRSC test cycle D2, E2 or G. The 50 % speed shall be calculated in accordance with point 5.2.5.1. in the case of an engine where MTS is used for the generation of test speeds, and calculated in accordance with point 7.7.1.3. in all other cases. 50 % torque is defined as 50 % of the maximum available torque at this speed. The emissions test shall be started without stopping the engine.

For engine categories NRS and NRSh the engine shall be warmed up according to the recommendation of the manufacturer and good engineering judgment. Before emission

sampling can start, the engine shall be running on mode 1 of the appropriate test cycle until engine temperatures have been stabilized. The emissions test shall be started without stopping the engine.

7.3.1.1.4. Preconditioning for RMC

The engine manufacturer shall select one of the following pre-conditioning sequences (a) or (b). The engine shall be pre-conditioned according to the chosen sequence.

- (a) The engine shall be preconditioned by running at least the second half of the RMC, based on the number of test modes. The engine shall not be shut down between cycles. Immediately after completing each preconditioning cycle, the next cycle (including the emission test) shall be started as soon as practical. Where possible, it is recommended that the next cycle be started within 60 seconds after completing the last preconditioning cycle.
- (b) The engine shall be warmed-up and run until engine temperatures (cooling water and lube oil) have been stabilized on 50 % speed and 50 % torque for any RMC test cycle other than type D2, E2, or G, or nominal engine speed and 50 % torque for any RMC test cycle D2, E2 or G. The 50 % speed shall be calculated in accordance with point 5.2.5.1. in the case of an engine where MTS is used for the generation of test speeds, and be calculated in accordance with point 7.7.1.3. in all other cases. 50 % torque is defined as 50 % of the maximum available torque at this speed.

7.3.1.1.5. Engine cool-down (NRTC)

A natural or forced cool-down procedure may be applied. For forced cool-down, good engineering judgment shall be used to set up systems to send cooling air across the engine, to send cool oil through the engine lubrication system, to remove heat from the coolant through the engine cooling system, and to remove heat from an exhaust after-treatment system. In the case of a forced after-treatment cool down, cooling air shall not be applied until the exhaust after-treatment system has cooled below its catalytic activation temperature. Any cooling procedure that results in unrepresentative emissions is not permitted.

7.3.1.2. Verification of HC contamination

If there is any presumption of an essential HC contamination of the exhaust gas measuring system, the contamination with HC may be checked with zero gas and the hang-up may then be corrected. If the amount of contamination of the measuring system and the background HC system has to be checked, it shall be conducted within 8 hours of starting each test-cycle. The values shall be recorded for later correction. Before this check, the leak check has to be performed and the FID analyzer has to be calibrated.

7.3.1.3. Preparation of measurement equipment for sampling

The following steps shall be taken before emission sampling begins:

- (a) Leak checks shall be performed within 8 hours prior to emission sampling according to point 8.1.8.7.;
- (b) For batch sampling, clean storage media shall be connected, such as evacuated bags or tare-weighed filters;
- (c) All measurement instruments shall be started according to the instrument manufacturer's instructions and good engineering judgment;
- (d) Dilution systems, sample pumps, cooling fans, and the data-collection system shall be started;
- (e) The sample flow rates shall be adjusted to desired levels, using bypass flow, if desired;
- (f) Heat exchangers in the sampling system shall be pre-heated or pre-cooled to within their operating temperature ranges for a test;
- (g) Heated or cooled components such as sample lines, filters, chillers, and pumps shall be allowed to stabilize at their operating temperatures;
- (h) Exhaust gas dilution system flow shall be switched on at least 10 minutes before a test sequence;
- (i) Calibration of gas analyzers and zeroing of continuous analyzers shall be carried out according to the procedure of the next point 7.3.1.4.;
- (j) Any electronic integrating devices shall be zeroed or re-zeroed, before the start of any test interval.

7.3.1.4. Calibration of gas analyzers

Appropriate gas analyzer ranges shall be selected. Emission analyzers with automatic or manual range switching are allowed. During a test using transient (NRTC or LSI-NRTC) test cycles or RMC and during a sampling period of a gaseous emission at the end of each mode for discrete-mode NRSC testing, the range of the emission analyzers may not be switched. Also the gains of an analyzer's analogue operational amplifier(s) may not be switched during a test cycle.

All continuous analyzers shall be zeroed and spanned using internationally-traceable gases that meet the specifications of point 9.5.1. FID analyzers shall be spanned on a carbon number basis of one (C_1).

7.3.1.5. PM filter preconditioning and tare weighing

The procedures for PM filter preconditioning and tare weighing shall be followed according to point 8.2.3..

7.3.2. Post-test procedures

The following steps shall be taken after emission sampling is complete:

7.3.2.1. Verification of proportional sampling

For any proportional batch sample, such as a bag sample or PM sample, it shall be verified that proportional sampling was maintained according to point 8.2.1.. For the single filter method and the discrete steady-state test cycle, effective PM weighting factor shall be calculated. Any sample that does not fulfil the requirements of point 8.2.1. shall be voided.

7.3.2.2. Post-test PM conditioning and weighing

Used PM sample filters shall be placed into covered or sealed containers or the filter holders shall be closed, in order to protect the sample filters against ambient contamination. Thus protected, the loaded filters have to be returned to the PM-filter conditioning chamber or room. Then the PM sample filters shall be conditioned and weighted accordingly to point 8.2.4. (PM filter post-conditioning and total weighing procedures).

7.3.2.3. Analysis of gaseous batch sampling

As soon as practical, the following shall be performed:

- (a) All batch gas analyzers shall be zeroed and spanned no later than 30 minutes after the test cycle is complete or during the soak period if practical to check if gaseous analyzers are still stable;
- (b) Any conventional gaseous batch samples shall be analyzed no later than 30 minutes after the hot-start NRTC is complete or during the soak period;
- (c) The background samples shall be analyzed no later than 60 minutes after the hot-start NRTC is complete.

7.3.2.4. Drift verification

After quantifying exhaust gas, drift shall be verified as follows:

- (a) For batch and continuous gas analyzers, the mean analyzer value shall be recorded after stabilizing a zero gas to the analyzer. Stabilization may include time to purge the analyzer of any sample gas, plus any additional time to account for analyzer response;
- (b) The mean analyzer value shall be recorded after stabilizing the span gas to the analyzer. Stabilization may include time to purge the analyzer of any sample gas, plus any additional time to account for analyzer response;
- (c) These data shall be used to validate and correct for drift as described in point 8.2.2..

7.4. Test cycles

The EU type-approval test shall be conducted using the appropriate NRSC and, where applicable, NRTC or LSI-NRTC, specified in Article 23 and Annex IV to Regulation 2016/1628. The technical specifications and characteristics of the NRSC, NRTC and LSI-NRTC are laid down in Annex XVII and the method for determination of the load and speed settings for these test cycles set out in section 5.2..

7.4.1. Steady-state test cycles

Non- road steady-state test cycles (NRSC) are specified in Appendices 1 and 2 of Annex XVII as a list of discrete-modes NRSC (operating points), where each operating point has one value of speed and one value of torque. A NRSC shall be measured with a warmed up and running engine according to manufacturer's specification. At the choice of the manufacturer, a NRSC may be run as a discrete-mode NRSC or a RMC, as explained in points 7.4.1.1. and 7.4.1.2.. It shall not be required to conduct an emission test according to both points 7.4.1.1. and 7.4.1.2..

7.4.1.1. Discrete-mode NRSC

The discrete-mode NRSC are hot running cycles where emissions shall be started to be measured after the engine is started, warmed up and running as specified in point 7.8.1.2.. Each cycle consists of a number of speed and load modes (with the respective weighing factor for each mode) which cover the typical operating range of the specified engine category.

7.4.1.2. Ramped modal NRSC

The RMC are hot running cycles where emissions shall be started to be measured after the engine is started, warmed up and running as specified in point 7.8.2.1.. The engine shall be continuously controlled by the test bed control unit during the RMC. The gaseous and particulate emissions shall be measured and sampled continuously during the RMC in the same way as in a transient (NRTC or LSI-NRTC) test cycles.

An RMC is intended to provide a method for performing a steady-state test in a pseudo-transient manner. Each RMC consists of a series of steady state modes with a linear transition between them. The relative total time at each mode and its preceding transition match the weighting of the discrete-mode NRSC. The change in engine speed and load from one mode to the next one has to be linearly controlled in a time of 20 ± 1 seconds. The mode change time is part of the new mode (including the first mode). In some cases modes are not run in the same order as the discrete-mode NRSC or are split to prevent extreme changes in temperature.

7.4.2. Transient (NRTC and LSI-NRTC) test cycles

The non-road transient cycle for engines of category NRE (NRTC) and the non-road transient cycle for large spark ignition engines of category NRS (LSI-NRTC) are each specified in Appendix 3 of Annex XVII as a second-by-second sequence of normalized

speed and torque values. In order to perform the test in an engine test cell, the normalized values shall be converted to their equivalent reference values for the individual engine to be tested, based on specific speed and torque values identified in the engine-mapping curve. The conversion is referred to as denormalization, and the resulting test cycle is the reference NRTC or LSI-NRTC test cycle of the engine to be tested (see point 7.7.2.).

7.4.2.1. Test sequence for NRTC

A graphical display of the normalized NRTC dynamometer schedule is shown in Figure 6.3..

Figure 6.3.

NRTC normalized dynamometer schedule

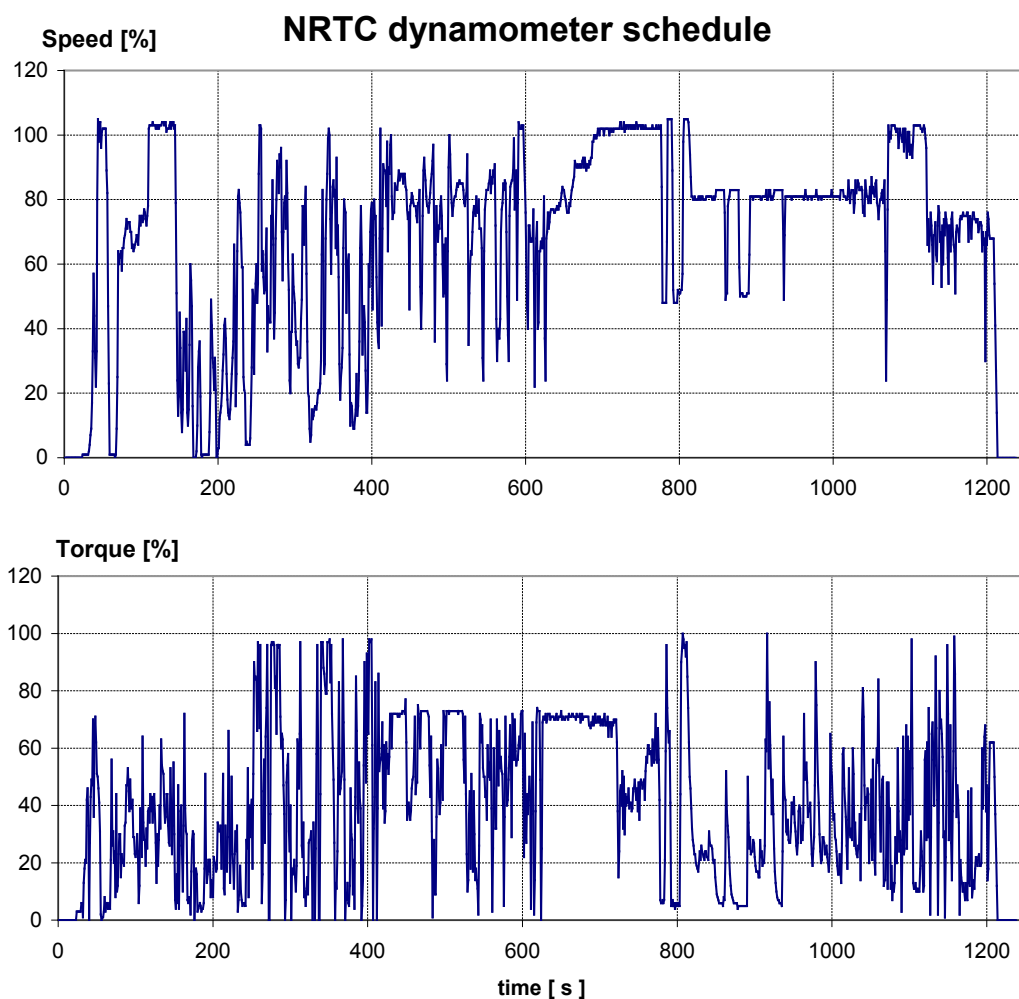

The NRTC shall be run twice after completion of pre-conditioning (see point 7.3.1.1.1.) in accordance with the following procedure:

- (a) the cold start after the engine and exhaust after-treatment systems have cooled down to room temperature after natural engine cool down, or the cold start after forced cool down and the engine, coolant and oil temperatures, exhaust after-treatment systems and all engine control devices are stabilized between 293 K and 303 K (20°C and 30 °C). The measurement of the cold start emissions shall be started with the start of the cold engine;

- (b) the hot soak period shall commence immediately upon completion of the cold start phase. The engine shall be shut-down and conditioned for the hot-start run by soaking it for 20 minutes \pm 1 minute;
- (c) the hot-start run shall be started immediately after the soak period with the cranking of the engine. The gaseous analyzers shall be switched on at least 10 seconds before the end of the soak period to avoid switching signal peaks. The measurement of emissions shall be started in parallel with the start of the hot-start NRTC, including the cranking of the engine.

Brake specific emissions expressed in (g/kWh) shall be determined by using the procedures set out in this section for both the cold-start and hot-start NRTC. Composite weighted emissions shall be computed by weighting the cold-start run results by 10 % and the hot-start run results by 90 % as detailed in Annex VII.

7.4.2.2. Test sequence for LSI-NRTC

The LSI-NRTC shall be run once as a hot-start run after completion of pre-conditioning (see point 7.3.1.1.2.) in accordance with the following procedure:

- (a) the engine shall be started and operated for the first 180 seconds of the duty cycle, then operated at idle without load for 30 seconds. Emissions shall not be measured during this warm-up sequence.
- (b) At the end of the 30-second idling period, emissions measurement shall be started and the engine be operated over the entire duty cycle from the beginning (time 0 sec).

Brake specific emissions expressed in (g/kWh) shall be determined by using the procedures of Annex VII.

If the engine was already operating before the test, use good engineering judgment to let the engine cool down enough so measured emissions will accurately represent those from an engine starting at room temperature. For example, if an engine starting at room temperature warms up enough in three minutes to start closed-loop operation and achieve full catalyst activity, then minimal engine cooling is necessary before starting the next test.

With the prior agreement of the technical service, the engine warm-up procedure may include up to 15 minutes of operation over the duty cycle.

7.5. General test sequence

To measure engine emissions the following steps have to be performed:

- (a) The engine test speeds and test loads have to be defined for the engine to be tested by measuring the max torque (for constant-speed engines) or max torque curve (for variable-speed engines) as function of the engine speed;

- (b) Normalized test cycles have to be denormalized with the torque (for constant-speed engines) or speeds and torques (for variable-speed engines) found in the previous point 7.5.(a);
- (c) The engine, equipment, and measurement instruments shall be prepared for the following emission test or test series (cold-start run and hot-start run) in advance;
- (d) Pre-test procedures shall be performed to verify proper operation of certain equipment and analyzers. All analysers have to be calibrated. All pre-test data shall be recorded;
- (e) The engine shall be started (NRTC) or kept running (steady-state cycles and LSI-NRTC) at the beginning of the test cycle and the sampling systems shall be started at the same time;
- (f) Emissions and other required parameters shall be measured or recorded during sampling time (for NRTC, LSI-NRTC and RMC throughout the whole test cycle);
- (g) Post-test procedures shall be performed to verify proper operation of certain equipment and analyzers;
- (h) PM filter(s) shall be pre-conditioned, weighed (empty weight), loaded, re-conditioned, again weighed (loaded weight) and then samples shall be evaluated according to pre- (para. 7.3.1.5.) and post-test (para. 7.3.2.2.) procedures;
- (i) Emission test results shall be evaluated.

Figure 6.4. gives an overview about the procedures needed to conduct NRMM test cycles with measuring exhaust engine emissions.

Figure 6.4.
Test sequence

Steady-state (discrete & RMC)

Generate engine map
(maximum torque curve or
constant speed operating line) if
transient cycle not applied

Define steady-state test cycle

Generate reference transient test cycle

Run one or more practice cycle as
necessary to check engine/test

Natural or forced cool
down

Ready all systems for sampling (analyzer calibration included) & data collection

Pre-condition & warm-up engine

Cold start exhaust
emission test phase

Exhaust emission test

Hot soak

Hot start exhaust
emission test phase

1) Data collection 2) Post-test procedures 3) Evaluations

Emissions calculation

EN

EN

7.5.1. Engine starting, and restarting

7.5.1.1. Engine start

The engine shall be started:

- (a) As recommended in the end-users' instructions using a production starter motor or air-start system and either an adequately charged battery, a suitable power supply or a suitable compressed air source; or
- (b) By using the dynamometer to crank the engine until it starts. Typically operate the engine within $\pm 25\%$ of its typical in-use cranking speed or start the engine by linearly increasing the dynamometer speed from zero to 100 min^{-1} below low idle speed but only until the engine starts.

Cranking shall be stopped within 1 s of starting the engine. If the engine does not start after 15 s of cranking, cranking shall be stopped and the reason for the failure to start determined, unless the end-users' instructions or the service-repair manual describes a longer cranking time as normal.

7.5.1.2. Engine stalling

- (a) If the engine stalls anywhere during the cold-start NRTC, the test shall be voided;
- (b) If the engine stalls anywhere during the hot-start NRTC, the test shall be voided. The engine shall be soaked according to point 7.4.2.1.(b), and the hot-start run repeated. In this case, the cold-start run does not need to be repeated;
- (c) If the engine stalls anywhere during the LSI-NRTC, the test shall be voided.
- (d) If the engine stalls anywhere during the NRSC (discrete or ramped), the test shall be voided and be repeated beginning with the engine warm-up procedure. In the case of PM measurement utilizing the multi-filter method (one sampling filter for each operating mode), the test shall be continued by stabilizing the engine at the previous mode for engine temperature conditioning and then initiating measurement with the mode where the engine stalled.

7.5.1.3 Engine operation

The "operator" may be a person (i.e., manual), or a governor (i.e., automatic) that mechanically or electronically signals an input that demands engine output. Input may be from an accelerator pedal or signal, a throttle-control lever or signal, a fuel lever or signal, a speed lever or signal, or a governor set point or signal.

7.6. Engine mapping

Before starting the engine mapping, the engine shall be warmed up and towards the end of the warm up it shall be operated for at least 10 minutes at maximum power or according to the recommendation of the manufacturer and good engineering judgement in order to stabilize the engine coolant and lube oil temperatures. When the engine is stabilized, the engine mapping shall be performed.

Where the manufacturer intends to use the torque signal broadcast by the electronic control unit, of engines so equipped, during the conduct of in-service monitoring tests according to Commission Delegated Regulation 2016/BBB on monitoring of emissions of in-service engines, the verification set out in Appendix 3 shall additionally be performed during the engine mapping.

Except constant-speed engines, engine mapping shall be performed with fully open fuel lever or governor using discrete speeds in ascending order. The minimum and maximum mapping speeds are defined as follows:

Minimum mapping speed = warm idle speed

Maximum mapping speed = $n_{hi} \times 1,02$ or speed where max torque drops off to zero, whichever is smaller.

Where:

n_{hi} is the high speed, as defined in Article 2(12).

If the highest speed is unsafe or unrepresentative (e.g., for ungoverned engines), good engineering judgement shall be used to map up to the maximum safe speed or the maximum representative speed.

7.6.1. Engine mapping for variable-speed NRSC

In the case of engine mapping for a variable-speed NRSC (only for engines which have not to run the NRTC or LSI-NRTC cycle), good engineering judgment shall be used to select a sufficient number of evenly spaced set-points. At each set-point, speed shall be stabilized and torque allowed to stabilize at least for 15 seconds. The mean speed and torque shall be recorded at each set-point. It is recommended that the mean speed and torque are calculated using the recorded data from the last 4 to 6 seconds. Linear interpolation shall be used to determine the NRSC test speeds and torques if needed. When engines are additionally required to run an NRTC or LSI-NRTC, the NRTC engine mapping curve shall be used to determine steady-state test speeds and torques.

At the choice of the manufacturer the engine mapping may alternatively be conducted according to the procedure in point 7.6.2..

7.6.2. Engine mapping for NRTC and LSI-NRTC

The engine mapping shall be performed according to the following procedure:

- (a) The engine shall be unloaded and operated at idle speed;
 - (i) For engines with a low-speed governor, the operator demand shall be set to the minimum, the dynamometer or another loading device shall be used to target a torque of zero on the engine's primary output shaft and the engine shall be allowed to govern the speed. This warm idle speed shall be measured;
 - (ii) For engines without a low-speed governor, the dynamometer shall be set to target a torque of zero on the engine's primary output shaft, and the operator demand shall be set to control the speed to the manufacturer-declared lowest engine speed possible with minimum load (also known as manufacturer-declared warm idle speed);
 - (iii) The manufacturer declared idle torque may be used for all variable-speed engines (with or without a low-speed governor), if a nonzero idle torque is representative of in-use operation;
- (b) Operator demand shall be set to maximum and engine speed shall be controlled to between warm idle and 95 % of its warm idle speed. For engines with reference duty cycles, which lowest speed is greater than warm idle speed, the mapping may be started at between the lowest reference speed and 95 % of the lowest reference speed;
- (c) The engine speed shall be increased at an average rate of $8 \pm 1 \text{ min}^{-1}/\text{s}$ or the engine shall be mapped by using a continuous sweep of speed at a constant rate such that it takes 4 to 6 min to sweep from minimum to maximum mapping speed. The mapping speed range shall be started between warm idle and 95 % of warm idle and ended at the highest speed above maximum power at which less than 70 % of maximum power occurs. If this highest speed is unsafe or unrepresentative (e.g., for ungoverned engines), good engineering judgment shall be used to map up to the maximum safe speed or the maximum representative speed. Engine speed and torque points shall be recorded at a sample rate of at least 1 Hz;
- (d) If a manufacturer believes that the above mapping techniques are unsafe or unrepresentative for any given engine, alternate mapping techniques may be used. These alternate techniques shall satisfy the intent of the specified mapping procedures to determine the maximum available torque at all engine speeds achieved during the test cycles. Deviations from the mapping techniques specified in this section for reasons of safety or representativeness shall be approved by the approval authority along with the justification for their use. In no case, however, the torque curve shall be run by descending engine speeds for governed or turbocharged engines;
- (e) An engine need not be mapped before each and every test cycle. An engine shall be remapped if:

- (i) an unreasonable amount of time has transpired since the last map, as determined by good engineering judgment; or
- (ii) physical changes or recalibrations have been made to the engine which potentially affect engine performance; or
- (iii) the atmospheric pressure near the engine's air inlet is not within ± 5 kPa of the value recorded at the time of the last engine map.

7.6.3. Engine mapping for constant-speed NRSC

The engine may be operated with a production constant-speed governor or a constant-speed governor maybe simulated by controlling engine speed with an operator demand control system. Either isochronous or speed-droop governor operation shall be used, as appropriate.

7.6.3.1. Rated power check for engines to be tested on cycles D2 or E2

The following check shall be conducted:

- (a) With the governor or simulated governor controlling speed using operator demand the engine shall be operated at the rated speed and the rated power for as long as required to achieve stable operation;
- (b) The torque shall be increased until the engine is unable to maintain the governed speed. The power at this point shall be recorded. Before this check is performed the method to safely determine when this point has been reached shall be agreed between the manufacturer and the technical service conducting the check, depending upon the characteristics of the governor. The power recorded at point (b) shall not exceed the rated power as defined in Article 3(25) of regulation (EU) 2016/1628 by more than 12,5 %. If this value is exceeded the manufacturer shall revise the declared rated power.

If the specific engine being tested is unable to perform this check due to risk of damage to the engine or dynamometer the manufacturer shall present to the approval authority robust evidence that maximum power does not exceed the rated power by more than 12,5 %.

7.6.3.2. Mapping procedure for constant-speed NRSC

- (a) With the governor or simulated governor controlling speed using operator demand, the engine shall be operated at no-load governed speed (at high speed, not low idle) for at least 15 seconds, unless the specific engine is unable to perform this task;
- (b) The dynamometer shall be used to increase torque at a constant rate. The map shall be conducted such that it takes no less than 2 min to sweep from no-load governed speed to the torque corresponding to rated power for engines to be

tested on cycle D2 or E2 or to maximum torque in the case of other constant-speed test cycles. During the engine mapping actual speed and torque shall be recorded with at least 1 Hz;

- (c) In case of a constant-speed engine with a governor that can be reset to alternative speeds, the engine shall be tested at each applicable constant-speed.

For constant-speed engines good engineering judgment shall be used in agreement with the approval authority to apply other methods to record torque and power at the defined operating speed(s).

For engines tested on cycles other than D2 or E2, when both measured and declared values are available for the maximum torque, the declared value may be used instead of the measured value if it is between 95 and 100 % of the measured value.

7.7. Test cycle generation

7.7.1. Generation of NRSC

This point shall be used to generate the engine speeds and loads over which the engine shall be operated during steady-state tests with discrete-mode NRSC or RMC.

7.7.1.1. Generation of NRSC test speeds for engines tested with both NRSC and either NRTC or LSI-NRTC.

For engines that are tested with either NRTC or LSI-NRTC in addition to a NRSC, the MTS specified in point 5.2.5.1. shall be used as the 100% speed for both transient and steady state tests.

The MTS shall be used in place of rated speed when determining intermediate speed in accordance with point 5.2.5.4..

The idle speed shall be determined in accordance with point 5.2.5.5..

7.7.1.2. Generation of NRSC test speeds for engines only tested with NRSC

For engines that are not tested with a transient (NRTC or LSI-NRTC) test cycle, the rated speed specified in point 5.2.5.3. shall be used as the 100% speed.

The rated speed shall be used to determine the intermediate speed in accordance with point 5.2.5.4.. If the NRSC specifies additional speeds as a percentage they shall be calculated as a percentage of the rated speed.

The idle speed shall be determined in accordance with point 5.2.5.5..

With prior approval of the technical service, MTS may be used instead of rated speed for the generation of test speeds in this point.

7.7.1.3. Generation of NRSC load for each test mode

The per cent load for each test mode of the chosen test cycle shall be taken from the appropriate NRSC Table of Appendix 1 or 2 of Annex XVII. Depending upon the test cycle, the per cent load in these Tables is expressed as either power or torque in accordance with point 5.2.6. and in the footnotes for each Table.

The 100% value at a given test speed shall be the measured or declared value taken from the mapping curve generated in accordance with point 7.6.1., point 7.6.2. or point 7.6.3. respectively, expressed as power (kW).

The engine setting for each test mode shall be calculated by means of equation (6-14):

$$S = \left((P_{\max} + P_{\text{AUX}}) \cdot \frac{L}{100} \right) - P_{\text{AUX}} \quad (6-14)$$

Where:

- S is the dynamometer setting in kW
- P_{\max} is the maximum observed or declared power at the test speed under the test conditions (specified by the manufacturer) in kW
- P_{AUX} is the declared total power absorbed by auxiliaries as defined in equation (6-8) (see point 6.3.5.) at the specified test speed in kW
- L is per cent torque

A warm minimum torque that is representative of in-use operation may be declared and used for any load point that would otherwise fall below this value if the engine type will not normally operate below this minimum torque, for example because it will be connected to a non-road mobile machinery that does not operate below a certain minimum torque.

In the case of cycles E2 and D2 the manufacturer shall declare the rated power and these shall be used as 100% power when generating the test cycle.

7.7.2. Generation of NRTC & LSI-NRTC speed and load for each test point (denormalization)

This point shall be used to generate the corresponding engine speeds and loads over which the engine shall be operated during NRTC or LSI-NRTC tests. Appendix 3 of Annex XVII defines applicable test cycles in a normalized format. A normalized test cycle consists of a sequence of paired values for speed and torque %.

Normalized values of speed and torque shall be transformed using the following conventions:

- (a) The normalized speed shall be transformed into a sequence of reference speeds, n_{ref} , in accordance with point 7.7.2.2.;
- (b) The normalized torque is expressed as a percentage of the mapped torque from the curve generated according to point 7.6.2. at the corresponding reference speed.

These normalized values shall be transformed into a sequence of reference torques, T_{ref} , according to point 7.7.2.3.;

- (c) The reference speed and reference torque values expressed in coherent units are multiplied to calculate the reference power values.

7.7.2.1. Reserved

7.7.2.2. Denormalization of engine speed

The engine speed shall be denormalized using by means of equation (6-15):

$$n_{ref} = \frac{\%speed \times (MTS - n_{idle})}{100} + n_{idle} \quad (6-15)$$

Where:

n_{ref}	is the reference speed
MTS	is the maximum test speed
n_{idle}	is the idle speed
$\%speed$	is the value of NRTC or LSI-NRTC normalized speed taken from Appendix 3 of Annex XVII.

7.7.2.3. Denormalization of engine torque

The torque values in the engine dynamometer schedule of Appendix 3 of Annex XVII. are normalized to the maximum torque at the respective speed. The torque values of the reference cycle shall be denormalized, using the mapping curve determined according to point 7.6.2., by means of equation (6-16):

$$T_{ref} = \frac{\%torque \cdot max.torque}{100} \quad (6-16)$$

for the respective reference speed as determined in point 7.7.2.2..

Where:

T_{ref}	is the reference torque for the respective reference speed
$max.torque$	is the maximum torque for the respective test speed taken from the engine mapping performed in accordance with point 7.6.2. adjusted where necessary in accordance with point 7.7.2.3.1..
$\%torque$	is the value of NRTC or LSI-NRTC normalized torque taken from Appendix 3 of Annex XVII

- (a) Declared minimum torque

A minimum torque that is representative of in-use operation may be declared. For example, if the engine is typically connected to a non-road mobile machinery that does

not operate below a certain minimum torque, this torque may be declared and used for any load point that would otherwise fall below this value.

(b) Adjustment of engine torque due to auxiliaries fitted for the emissions test

Where auxiliaries are fitted in accordance with Appendix 2 there shall be no adjustment to the maximum torque for the respective test speed taken from the engine mapping performed according to point 7.6.2..

Where, according to points 6.3.2. or 6.3.3. necessary auxiliaries that should have been fitted for the test are not installed, or auxiliaries that should have been removed for the test are installed, the value of T_{\max} shall be adjusted by means of equation (6-17).

$$T_{\max} = T_{\text{map}} - T_{\text{AUX}} \quad (6-17)$$

with:

$$T_{\text{AUX}} = T_r - T_f \quad (6-18)$$

where:

T_{map} is the unadjusted maximum torque for the respective test speed taken from the engine mapping performed in accordance with point 7.6.2.

T_f is the torque required to drive auxiliaries that should have been fitted but were not installed for the test

T_r is the torque required to drive auxiliaries that should have been removed for the test but were installed for the test

7.7.2.4. Example of denormalization procedure

As an example, the following test point shall be denormalized:

$$\% \text{ speed} = 43 \%$$

$$\% \text{ torque} = 82 \%$$

Given the following values:

$$MTS = 2200 \text{ min}^{-1}$$

$$n_{\text{idle}} = 600 \text{ min}^{-1}$$

results in

$$n_{\text{ref}} = \frac{43 \cdot (2200 - 600)}{100} + 600 = 1288 \text{ min}^{-1}$$

With the maximum torque of 700 Nm observed from the mapping curve at 1288 min^{-1}

$$T_{ref} = \frac{82 \times 700}{100} = 574 \text{ Nm}$$

7.8. Specific test cycle running procedure

7.8.1. Emission test sequence for discrete-mode NRSC

7.8.1.1. Engine warming-up for steady state discrete-mode NRSC

Pre-test procedure according to point 7.3.1. shall be performed, including analyzer calibration. The engine shall be warmed-up using the pre-conditioning sequence in point 7.3.1.1.3.. Immediately from this engine conditioning point, the test cycle measurement starts.

7.8.1.2. Performing discrete-mode NRSC

- (a) The test shall be performed in ascending order of mode numbers as set out for the test cycle (see Appendix 1 of Annex XVII.);
- (b) Each mode has a mode length of at least 10 minutes, except when testing spark ignition engines using cycles G1, G2 or G3 where each mode has a length of at least 3 minutes. In each mode the engine shall be stabilized for at least 5 minutes and emissions shall be sampled for 1-3 minutes for gaseous emissions and, where there is an applicable limit, PN at the end of each mode, except when testing spark ignition engines using cycles G1, G2 or G3 where emissions shall be sampled for at least the last 2 minutes of the respective test mode. Extended time of sampling is permitted to improve the accuracy of PM sampling;

The mode length shall be recorded and reported.

- (c) The PM sampling may be done either with the single filter method or with the multiple filter method. Since the results of the methods may differ slightly, the method used shall be declared with the results;

For the single filter method the modal weighting factors specified in the test cycle procedure and the actual exhaust gas flow shall be taken into account during sampling by adjusting sample flow rate and/or sampling time, accordingly. It is required that the effective weighing factor of the PM sampling is within $\pm 0,005$ of the weighing factor of the given mode;

Sampling shall be conducted as late as possible within each mode. For the single filter method, the completion of PM sampling shall be coincident within ± 5 s with the completion of the gaseous emission measurement. The sampling time per mode shall be at least 20 s for the single filter method and at least 60 s for the multi-filter method. For systems without bypass capability, the sampling time per mode shall be at least 60 s for single and multiple filter methods;

- (d) The engine speed and load, intake air temperature, fuel flow and where applicable air or exhaust gas flow shall be measured for each mode at the same time interval which is used for the measurement of the gaseous concentrations;

Any additional data required for calculation shall be recorded.

- (e) If the engine stalls or the emission sampling is interrupted at any time after emission sampling begins for a discrete-mode NRSC and the single filter method, the test shall be voided and be repeated beginning with the engine warm-up procedure. In the case of PM measurement utilizing the multi-filter method (one sampling filter for each operating mode), the test shall be continued by stabilizing the engine at the previous mode for engine temperature conditioning and then initiating measurement with the mode where the engine stalled;
- (f) Post-test procedures according to point 7.3.2. shall be performed.

7.8.1.3. Validation criteria

During each mode of the given steady-state test cycle after the initial transition period, the measured speed shall not deviate from the reference speed for more than $\pm 1\%$ of rated speed or $\pm 3 \text{ min}^{-1}$, whichever is greater except for idle which shall be within the tolerances declared by the manufacturer. The measured torque shall not deviate from the reference torque for more than $\pm 2\%$ of the maximum torque at the test speed.

7.8.2. Emission test sequence for RMC

7.8.2.1. Engine warming-up

Pre-test procedure according to point 7.3.1. shall be performed, including analyzer calibration. The engine shall be warmed-up using the pre-conditioning sequence in point 7.3.1.1.4.. Immediately after this engine conditioning procedure, if the engine speed and torque are not already set for the first mode of the test they shall be changed in a linear ramp of $20 \pm 1 \text{ s}$ to the first mode of the test. In between 5 to 10 s after the end of the ramp, the test cycle measurement shall start.

7.8.2.2. Performing a RMC

The test shall be performed in the order of mode numbers as set out for the test cycle (see Appendix 2 of Annex XVII.) Where there is no RMC available for the specified NRSC the discrete-mode NRSC procedure set out in point 7.8.1. shall be followed.

The engine shall be operated for the prescribed time in each mode. The transition from one mode to the next shall be done linearly in $20 \text{ s} \pm 1 \text{ s}$ following the tolerances prescribed in point 7.8.2.4..

For RMC, reference speed and torque values shall be generated at a minimum frequency of 1 Hz and this sequence of points shall be used to run the cycle. During the transition between modes, the denormalized reference speed and torque values shall be linearly

ramped between modes to generate reference points. The normalized reference torque values shall not be linearly ramped between modes and then denormalized. If the speed and torque ramp runs through a point above the engine's torque curve, it shall be continued to command the reference torques and it shall be allowed for the operator demand to go to maximum.

Over the whole RMC (during each mode and including the ramps between the modes), the concentration of each gaseous pollutant shall be measured and where there is an applicable limit the PM and PN be sampled. The gaseous pollutants may be measured raw or diluted and be recorded continuously; if diluted, they can also be sampled into a sampling bag. The particulate sample shall be diluted with conditioned and clean air. One sample over the complete test procedure shall be taken, and, in the case of PM collected on a single PM sampling filter.

For calculation of the brake specific emissions, the actual cycle work shall be calculated by integrating actual engine power over the complete cycle.

7.8.2.3. Emission test sequence

- (a) Execution of the RMC, sampling exhaust gas, recording data, and integrating measured values shall be started simultaneously;
- (b) Speed and torque shall be controlled to the first mode in the test cycle;
- (c) If the engine stalls anywhere during the RMC execution, the test shall be voided. The engine shall be pre-conditioned and the test repeated;
- (d) At the end of the RMC, sampling shall be continued, except for PM sampling, operating all systems to allow system response time to elapse. Then all sampling and recording shall be stopped, including the recording of background samples. Finally, any integrating devices shall be stopped and the end of the test cycle shall be indicated in the recorded data;
- (e) Post-test procedures according to point 7.3.2. shall be performed.

7.8.2.4. Validation criteria

RMC tests shall be validated using the regression analysis as described in points 7.8.3.3. and 7.8.3.5.. The allowed RMC tolerances are given in the following Table 6.1.. Note that the RMC tolerances are different from the NRTC tolerances of Table 6.2.. When conducting testing of engines of net power greater than 560 kW the regression line tolerances of Table 6.2. and the point deletion of Table 6.3. may be used.

Table 6.1.

RMC Regression line tolerances

	Speed	Torque	Power
Standard error of	maximum 1 % of	maximum 2 % of	maximum 2 % of

estimate (SEE) of y on x	rated speed	maximum engine torque	maximum engine power
Slope of the regression line, a_1	0,99 to 1,01	0,98 – 1,02	0,98 – 1,02
Coefficient of determination, r^2	minimum 0,990	minimum 0,950	minimum 0,950
y intercept of the regression line, a_0	± 1 % of rated speed	± 20 Nm or 2 % of maximum torque whichever is greater	± 4 kW or 2 % of maximum power whichever is greater

In case of running the RMC test not on a transient test bed, where the second by second speed and torque values are not available, the following validation criteria shall be used.

At each mode the requirements for the speed and torque tolerances are given in point 7.8.1.3.. For the 20 s linear speed and linear torque transitions between the RMC steady-state test modes (point 7.4.1.2.) the following tolerances for speed and load shall be applied for the ramp:

- (a) the speed shall be held linear within ± 2 % of rated speed,
- (b) the torque shall be held linear within ± 5 % of the maximum torque at rated speed.

7.8.3. Transient (NRTC and LSI-NRTC) test cycles

Reference speeds and torques commands shall be sequentially executed to perform the NRTC and LSI-NRTC. Speed and torque commands shall be issued at a frequency of at least 5 Hz. Because the reference test cycle is specified at 1 Hz, the in between speed and torque commands shall be linearly interpolated from the reference torque values generated from cycle generation.

Small denormalized speed values near warm idle speed may cause low-speed idle governors to activate and the engine torque to exceed the reference torque even though the operator demand is at a minimum. In such cases, it is recommended to control the dynamometer so it gives priority to follow the reference torque instead of the reference speed and let the engine govern the speed.

Under cold-start conditions engines may use an enhanced-idle device to quickly warm up the engine and the exhaust after-treatment system. Under these conditions, very low normalized speeds will generate reference speeds below this higher enhanced idle speed. In this case it is recommended controlling the dynamometer so it gives priority to follow the reference torque and let the engine govern the speed when the operator demand is at minimum.

During an emission test, reference speeds and torques and the feedback speeds and torques shall be recorded with a minimum frequency of 1 Hz, but preferably of 5 Hz or even 10 Hz. This larger recording frequency is important as it helps to minimize the

biasing effect of the time lag between the reference and the measured feedback speed and torque values.

The reference and feedback speeds and torques may be recorded at lower frequencies (as low as 1 Hz), if the average values over the time interval between recorded values are recorded. The average values shall be calculated based on feedback values updated at a frequency of at least 5 Hz. These recorded values shall be used to calculate cycle-validation statistics and total work.

7.8.3.1. Performing an NRTC test

Pre-test procedures according to point 7.3.1. shall be performed, including pre-conditioning, cool-down and analyzer calibration.

Testing shall be started as follows:

The test sequence shall commence immediately after the engine has started from cooled down condition specified in point 7.3.1.2. in case of the cold-start NRTC or from hot soak condition in case of the hot-start NRTC. The sequence in point 7.4.2.1. shall be followed.

Data logging, sampling of exhaust gas and integrating measured values shall be initiated simultaneously at the start of the engine. The test cycle shall be initiated when the engine starts and shall be executed according to the schedule of Appendix 3 of Annex XVII.

At the end of the cycle, sampling shall be continued, operating all systems to allow system response time to elapse. Then all sampling and recording shall be stopped, including the recording of background samples. Finally, any integrating devices shall be stopped and the end of the test cycle shall be indicated in the recorded data.

Post-test procedures according to point 7.3.2. shall be performed.

7.8.3.2. Performing an LSI-NRTC test

Pre-test procedures according to point 7.3.1. shall be performed, including pre-conditioning and analyzer calibration.

Testing shall be started as follows:

The test shall commence according to the sequence given in point 7.4.2.2..

Data logging, sampling of exhaust gas and integrating measured values shall be initiated simultaneously with the start of the LSI-NRTC at the end of the 30-second idle period specified in point 7.4.2.2.(b). The test cycle shall be executed according to the schedule of Appendix 3 of Annex XVII.

At the end of the cycle, sampling shall be continued, operating all systems to allow system response time to elapse. Then all sampling and recording shall be stopped, including the recording of background samples. Finally, any integrating devices shall be stopped and the end of the test cycle shall be indicated in the recorded data.

Post-test procedures according to point 7.3.2. shall be performed.

7.8.3.3. Cycle validation criteria for transient (NRTC and LSI-NRTC) test cycles

In order to check the validity of a test, the cycle-validation criteria in this point shall be applied to the reference and feedback values of speed, torque, power and overall work.

7.8.3.4. Calculation of cycle work

Before calculating the cycle work, any speed and torque values recorded during engine starting shall be omitted. Points with negative torque values have to be accounted for as zero work. The actual cycle work W_{act} (kWh) shall be calculated based on engine feedback speed and torque values. The reference cycle work W_{ref} (kWh) shall be calculated based on engine reference speed and torque values. The actual cycle work W_{act} is used for comparison to the reference cycle work W_{ref} and for calculating the brake specific emissions (see point 7.2.).

W_{act} shall be between 85 % and 105 % of W_{ref} .

7.8.3.5. Validation statistics (see Appendix 2 of Annex VII)

Linear regression between the reference and the feedback values shall be calculated for speed, torque and power.

To minimize the biasing effect of the time lag between the reference and feedback cycle values, the entire engine speed and torque feedback signal sequence may be advanced or delayed in time with respect to the reference speed and torque sequence. If the feedback signals are shifted, both speed and torque shall be shifted by the same amount in the same direction.

The method of least squares shall be used, with the best-fit equation having the form set out in equation (6-19):

$$y = a_1x + a_0 \quad (6-19)$$

where:

y	is the feedback value of speed (min^{-1}), torque (Nm), or power (kW)
a_1	is the slope of the regression line
x	is the reference value of speed (min^{-1}), torque (Nm), or power (kW)
a_0	is the y intercept of the regression line

The standard error of estimate (*SEE*) of *y* on *x* and the coefficient of determination (r^2) shall be calculated for each regression line in accordance with Appendix 3 of Annex VII.

It is recommended that this analysis be performed at 1 Hz. For a test to be considered valid, the criteria of Table 6.2. shall be met.

Table 6.2.
Regression line tolerances

	Speed	Torque	Power
Standard error of estimate (<i>SEE</i>) of <i>y</i> on <i>x</i>	≤ 5,0 percent of maximum test speed	≤ 10,0 % of maximum mapped torque	≤ 10,0 % of maximum mapped power
Slope of the regression line, a_1	0,95 to 1,03	0,83 – 1,03	0,89 – 1,03
Coefficient of determination, r^2	minimum 0,970	minimum 0,850	minimum 0,910
<i>y</i> intercept of the regression line, a_0	≤ 10 % of idle	± 20 Nm or ± 2 % of maximum torque whichever is greater	± 4 kW or ± 2 % of maximum power whichever is greater

For regression purposes only, point deletions are permitted where noted in Table 6.3. before doing the regression calculation. However, those points shall not be deleted for the calculation of cycle work and emissions. An idle point is defined as a point having a normalized reference torque of 0 % and a normalized reference speed of 0 %. Point deletion may be applied to the whole or to any part of the cycle; points to which the point deletion is applied have to be specified.

Table 6.3.
Permitted point deletions from regression analysis

Event	Conditions (n = engine speed, T = torque)	Permitted point deletions
Minimum operator demand (idle point)	$n_{\text{ref}} = n_{\text{idle}}$ and $T_{\text{ref}} = 0 \%$ and $T_{\text{act}} > (T_{\text{ref}} - 0,02 T_{\text{maxmappedtorque}})$ and $T_{\text{act}} < (T_{\text{ref}} + 0,02 T_{\text{maxmappedtorque}})$	speed and power
Minimum operator demand	$n_{\text{act}} \leq 1,02 n_{\text{ref}}$ and $T_{\text{act}} > T_{\text{ref}}$ or $n_{\text{act}} > n_{\text{ref}}$ and $T_{\text{act}} \leq T_{\text{ref}}$ or $n_{\text{act}} > 1,02 n_{\text{ref}}$ and $T_{\text{ref}} < T_{\text{act}} \leq (T_{\text{ref}} + 0,02 T_{\text{maxmappedtorque}})$	power and either torque or speed
Maximum operator demand	$n_{\text{act}} < n_{\text{ref}}$ and $T_{\text{act}} \geq T_{\text{ref}}$ or $n_{\text{act}} \geq 0,98 n_{\text{ref}}$ and $T_{\text{act}} < T_{\text{ref}}$ or $n_{\text{act}} < 0,98 n_{\text{ref}}$ and $T_{\text{ref}} > T_{\text{act}} \geq (T_{\text{ref}} - 0,02 T_{\text{maxmappedtorque}})$	power and either torque or speed

8. Measurement procedures

8.1. Calibration and performance checks

8.1.1. Introduction

This point describes required calibrations and verifications of measurement systems. See point 9.4. for specifications that apply to individual instruments.

Calibrations or verifications shall be generally performed over the complete measurement chain.

If a calibration or verification for a portion of a measurement system is not specified, that portion of the system shall be calibrated and its performance verified at a frequency consistent with any recommendations from the measurement system manufacturer and consistent with good engineering judgment.

Internationally recognized-traceable standards shall be used to meet the tolerances specified for calibrations and verifications.

8.1.2. Summary of calibration and verification

Table 6.4. summarizes the calibrations and verifications described in section 8. and indicates when these have to be performed.

Table 6.4.

Summary of Calibration and Verifications

Type of calibration or verification	Minimum frequency ^(a)
8.1.3.: accuracy, repeatability and noise	<p>Accuracy: Not required, but recommended for initial installation.</p> <p>Repeatability: Not required, but recommended for initial installation.</p> <p>Noise: Not required, but recommended for initial installation.</p>
8.1.4.: linearity verification	<p>Speed: Upon initial installation, within 370 days before testing and after major maintenance.</p> <p>Torque: Upon initial installation, within 370 days before testing and after major maintenance.</p> <p>Intake air, dilution air and diluted exhaust gas flows and batch sample flow rates: Upon initial installation, within 370 days before testing and after major maintenance, unless flow is verified by propane check or by carbon or oxygen balance.</p> <p>Raw exhaust gas flow: Upon initial installation, within 185 days before testing and after major maintenance, unless flow is verified by propane check or by carbon or oxygen balance.</p> <p>Gas dividers: Upon initial installation, within 370 days before testing and after major maintenance.</p> <p>Gas analyzers (unless otherwise noted): Upon initial installation, within 35 days before testing and after major maintenance.</p> <p>FTIR analyser: Upon installation, within 370 days before testing and after major maintenance.</p> <p>PM balance: Upon initial installation, within 370 days before testing and after major maintenance.</p> <p>Stand-alone pressure and temperature: Upon initial installation, within 370 days before testing and after major maintenance.</p>
8.1.5.: Continuous gas analyzer system response and updating-recording verification – for gas analyzers not continuously compensated for other gas species	<p>Upon initial installation or after system modification that would affect response.</p>
8.1.6.: Continuous gas analyzer system response and updating-recording verification – for gas analyzers continuously compensated for other gas species	<p>Upon initial installation or after system modification that would affect response.</p>
8.1.7.1.: torque	<p>Upon initial installation and after major maintenance.</p>

Type of calibration or verification	Minimum frequency ^(a)
8.1.7.2.: pressure, temperature, dew point	Upon initial installation and after major maintenance.
8.1.8.1.: fuel flow	Upon initial installation and after major maintenance.
8.1.8.2.: intake flow	Upon initial installation and after major maintenance.
8.1.8.3.: exhaust gas flow	Upon initial installation and after major maintenance.
8.1.8.4.: diluted exhaust gas flow (CVS and PFD)	Upon initial installation and after major maintenance.
8.1.8.5.: CVS/PFD and batch sampler verification ^(b)	Upon initial installation, within 35 days before testing, and after major maintenance. (Propane check)
8.1.8.8.: vacuum leak	Upon installation of the sampling system. Before each laboratory test according to point 7.1: within 8 hours before the start of the first test interval of each duty cycle sequence and after maintenance such as pre-filter changes.
8.1.9.1.: CO ₂ NDIR H ₂ O interference	Upon initial installation and after major maintenance.
8.1.9.2.: CO NDIR CO ₂ and H ₂ O interference	Upon initial installation and after major maintenance.
8.1.10.1.: FID calibration HC FID optimization and HC FID verification	Calibrate, optimize, and determine CH ₄ response: upon initial installation and after major maintenance. Verify CH ₄ response: upon initial installation, within 185 days before testing, and after major maintenance.
8.1.10.2.: raw exhaust gas FID O ₂ interference	For all FID analyzers: upon initial installation, and after major maintenance. For THC FID analyzers: upon initial installation, after major maintenance, and after FID optimization according to 8.1.10.1.
8.1.11.1.: CLD CO ₂ and H ₂ O quench	Upon initial installation and after major maintenance.
8.1.11.3.: NDUV HC and H ₂ O interference	Upon initial installation and after major maintenance.
8.1.11.4.: cooling bath NO ₂ penetration (chiller)	Upon initial installation and after major maintenance.
8.1.11.5.: NO ₂ -to-NO converter conversion	Upon initial installation, within 35 days before testing, and after major maintenance.
8.1.12.1.: Sample dryer verification	For thermal chillers: upon installation and after major maintenance. For osmotic membranes: upon installation, within 35 days of testing and after major maintenance
8.1.13.1.: PM balance and weighing	Independent verification: upon initial installation, within 370 days before testing, and after major maintenance. Zero, span, and reference sample verifications: within 12 hours of weighing, and after major maintenance.

Type of calibration or verification	Minimum frequency ^(a)
(a) Perform calibrations and verifications more frequently, according to measurement system manufacturer instructions and good engineering judgment.	
(b) The CVS verification is not required for systems that agree within $\pm 2\%$ based on a chemical balance of carbon or oxygen of the intake air, fuel, and diluted exhaust gas.	

8.1.3. Verifications for accuracy, repeatability, and noise

The performance values for individual instruments specified in Table 6.8. are the basis for the determination of the accuracy, repeatability, and noise of an instrument.

It is not required to verify instrument accuracy, repeatability, or noise. However, it may be useful to consider these verifications to define a specification for a new instrument, to verify the performance of a new instrument upon delivery, or to troubleshoot an existing instrument.

8.1.4. Linearity verification

8.1.4.1. Scope and frequency

A linearity verification shall be performed on each measurement system listed in Table 6.5. at least as frequently as indicated in the Table, consistent with measurement system manufacturer recommendations and good engineering judgment. The intent of a linearity verification is to determine that a measurement system responds proportionally over the measurement range of interest. A linearity verification shall consist of introducing a series of at least 10 reference values to a measurement system, unless otherwise specified. The measurement system quantifies each reference value. The measured values shall be collectively compared to the reference values by using a least squares linear regression and the linearity criteria specified in Table 6.5..

8.1.4.2. Performance requirements

If a measurement system does not meet the applicable linearity criteria in Table 6.5., the deficiency shall be corrected by re-calibrating, servicing, or replacing components as needed. The linearity verification shall be repeated after correcting the deficiency to ensure that the measurement system meets the linearity criteria.

8.1.4.3. Procedure

The following linearity verification protocol shall be used:

- (a) A measurement system shall be operated at its specified temperatures, pressures, and flows;
- (b) The instrument shall be zeroed as it would before an emission test by introducing a zero signal. For gas analyzers, a zero gas shall be used that meets the specifications of point 9.5.1. and it shall be introduced directly at the analyzer port;
- (c) The instrument shall be spanned as it would before an emission test by introducing a span signal. For gas analyzers, a span gas shall be used that meets the specifications of point 9.5.1. and it shall be introduced directly at the analyzer port;

- (d) After spanning the instrument, zero shall be checked with the same signal which has been used in paragraph (b) of this point. Based on the zero reading, good engineering judgment shall be used to determine whether or not to re-zero and or re-span the instrument before proceeding to the next step;
- (e) For all measured quantities manufacturer recommendations and good engineering judgment shall be used to select the reference values, y_{refi} , that cover the full range of values that are expected during emission testing, thus avoiding the need of extrapolation beyond these values. A zero reference signal shall be selected as one of the reference values of the linearity verification. For stand-alone pressure and temperature linearity verifications, at least three reference values shall be selected. For all other linearity verifications, at least ten reference values shall be selected;
- (f) Instrument manufacturer recommendations and good engineering judgment shall be used to select the order in which the series of reference values will be introduced;
- (g) Reference quantities shall be generated and introduced as described in point 8.1.4.4.. For gas analyzers, gas concentrations known to be within the specifications of point 9.5.1. shall be used and they shall be introduced directly at the analyzer port;
- (h) Time for the instrument to stabilize while it measures the reference value shall be allowed;
- (i) At a recording frequency of at least the minimum frequency, as specified in Table 6.7., the reference value shall be measured for 30 s and the arithmetic mean of the recorded values, \bar{y}_i recorded;
- (j) Steps in paragraphs (g) to (i) of this point shall be repeated until all reference quantities are measured;
- (k) The arithmetic means \bar{y}_i , and reference values, y_{refi} , shall be used to calculate least-squares linear regression parameters and statistical values to compare to the minimum performance criteria specified in Table 6.5.. The calculations described in Appendix 3 of Annex VII shall be used.

8.1.4.4. Reference signals

This point describes recommended methods for generating reference values for the linearity-verification protocol in point 8.1.4.3.. Reference values shall be used that simulate actual values, or an actual value shall be introduced and measured with a reference-measurement system. In the latter case, the reference value is the value reported by the reference-measurement system. Reference values and reference-measurement systems shall be internationally traceable.

For temperature measurement systems with sensors like thermocouples, RTDs, and thermistors, the linearity verification may be performed by removing the sensor from the system and using a simulator in its place. A simulator that is independently calibrated and cold junction compensated, as necessary shall be used. The internationally traceable simulator uncertainty scaled to temperature shall be less than 0,5 % of maximum operating temperature T_{\max} . If this option is used, it is necessary to use sensors that the supplier states are accurate to better than 0,5 % of T_{\max} compared to their standard calibration curve.

8.1.4.5. Measurement systems that require linearity verification

Table 6.5. indicates measurement systems that require linearity verifications. For this Table the following provisions shall apply:

- (a) a linearity verification shall be performed more frequently if the instrument manufacturer recommends it or based on good engineering judgment;
- (b) "min" refers to the minimum reference value used during the linearity verification;
Note that this value may be zero or a negative value depending on the signal;
- (c) "max" generally refers to the maximum reference value used during the linearity verification. For example for gas dividers, x_{\max} is the undivided, undiluted, span gas concentration. The following are special cases where "max" refers to a different value:
 - (i) For PM balance linearity verification, m_{\max} refers to the typical mass of a PM filter;
 - (ii) For torque linearity verification, T_{\max} refers to the manufacturer's specified engine torque peak value of the highest torque engine to be tested;
- (d) the specified ranges are inclusive. For example, a specified range of 0,98-1,02 for the slope a_1 means $0,98 \leq a_1 \leq 1,02$;
- (e) these linearity verifications are not required for systems that pass the flow-rate verification for diluted exhaust gas as described in point 8.1.8.5. for the propane check or for systems that agree within ± 2 % based on a chemical balance of carbon or oxygen of the intake air, fuel, and exhaust gas;
- (f) a_1 criteria for these quantities shall be met only if the absolute value of the quantity is required, as opposed to a signal that is only linearly proportional to the actual value;
- (g) stand-alone temperatures include engine temperatures and ambient conditions used to set or verify engine conditions; temperatures used to set or verify critical conditions in the test system; and temperatures used in emissions calculations:

- (i) these temperature linearity checks are required. Air intake; after-treatment bed(s) (for engines tested with exhaust after-treatment systems on cycles with cold start criteria); dilution air for PM sampling (CVS, double dilution, and partial flow systems); PM sample; and chiller sample (for gaseous sampling systems that use chillers to dry samples);
 - (ii) these temperature linearity checks are only required if specified by the engine manufacturer. Fuel inlet; test cell charge air cooler air outlet (for engines tested with a test cell heat exchanger simulating a non-road mobile machinery charge air cooler); test cell charge air cooler coolant inlet (for engines tested with a test cell heat exchanger simulating a non-road mobile machinery charge air cooler); and oil in the sump/pan; coolant before the thermostat (for liquid cooled engines);
- (h) stand-alone pressures include engine pressures and ambient conditions used to set or verify engine conditions; pressures used to set or verify critical conditions in the test system; and pressures used in emissions calculations:
- (i) required pressure linearity checks are: air intake pressure restriction; exhaust gas back-pressure; barometer; CVS inlet gage pressure (if measurement using CVS); chiller sample (for gaseous sampling systems that use chillers to dry samples);
 - (ii) pressure linearity checks that are required only if specified by the engine manufacturer: test cell charge air cooler and interconnecting pipe pressure drop (for turbo-charged engines tested with a test cell heat exchanger simulating a non-road mobile machinery charge air cooler) fuel inlet; and fuel outlet.

Table 6.5.

Measurement systems that require linearity verifications

Measurement System	Quantity	Minimum verification frequency	Linearity Criteria			
			$ x_{\min} \cdot (a_1 - 1) + a_0 $	a	SEE	r^2
Engine speed	n	Within 370 days before testing	$\leq 0,05 \% n_{\max}$	0,98-1,02	$\leq 2 \% n_{\max}$	$\geq 0,990$
Engine torque	T	Within 370 days before testing	$\leq 1 \% T_{\max}$	0,98-1,02	$\leq 2 \% T_{\max}$	$\geq 0,990$
Fuel flow rate	q_m	Within 370 days before testing	$\leq 1 \% q_{m, \max}$	0,98-1,02	$\leq 2 \% q_{m, \max}$	$\geq 0,990$
Intake-air flow rate ¹	q_v	Within 370 days before testing	$\leq 1 \% q_{v, \max}$	0,98-1,02	$\leq 2 \% q_{v, \max}$	$\geq 0,990$
Dilution air flow rate ¹	q_v	Within 370 days before testing	$\leq 1 \% q_{v, \max}$	0,98-1,02	$\leq 2 \% q_{v, \max}$	$\geq 0,990$
Diluted exhaust gas flow rate ¹	q_v	Within 370 days before testing	$\leq 1 \% q_{v, \max}$	0,98-1,02	$\leq 2 \% q_{v, \max}$	$\geq 0,990$
Raw exhaust gas flow rate ¹	q_v	Within 185 days before testing	$\leq 1 \% q_{v, \max}$	0,98-1,02	$\leq 2 \% q_{v, \max}$	$\geq 0,990$
Batch sampler flow rates ¹	q_v	Within 370 days before testing	$\leq 1 \% q_{v, \max}$	0,98-1,02	$\leq 2 \% q_{v, \max}$	$\geq 0,990$
Gas dividers	x/x_{span}	Within 370 days before testing	$\leq 0,5 \% x_{\max}$	0,98-1,02	$\leq 2 \% x_{\max}$	$\geq 0,990$
Gas analyzers	x	Within 35 days before testing	$\leq 0,5 \% x_{\max}$	0,99-1,01	$\leq 1 \% x_{\max}$	$\geq 0,998$
PM balance	m	Within 370 days before testing	$\leq 1 \% m_{\max}$	0,99-1,01	$\leq 1 \% m_{\max}$	$\geq 0,998$
Stand-alone pressures	p	Within 370 days before testing	$\leq 1 \% p_{\max}$	0,99-1,01	$\leq 1 \% p_{\max}$	$\geq 0,998$
Analog-to-digital conversion of stand-alone temperature signals	T	Within 370 days before testing	$\leq 1 \% T_{\max}$	0,99-1,01	$\leq 1 \% T_{\max}$	$\geq 0,998$

¹ Molar flow rate may be used instead of standard volumetric flow rate as the term representing 'quantity'. In this case maximum molar flow rate may be used instead of the maximum standard volumetric flow rate in the corresponding linearity criteria.

8.1.5. Continuous gas analyser system-response and updating-recording verification

This section describes a general verification procedure for continuous gas analyzer system response and update recording. See point 8.1.6. for verification procedures for compensation type analysers.

8.1.5.1. Scope and frequency

This verification shall be performed after installing or replacing a gas analyzer that is used for continuous sampling. Also this verification shall be performed if the system is reconfigured in a way that would change system response. This verification is needed for continuous gas analysers used for transient (NRTC and LSI-NRTC) test cycles or RMC but is not needed for batch gas analyzer systems or for continuous gas analyzer systems used only for testing with a discrete-mode NRSC.

8.1.5.2. Measurement principles

This test verifies that the updating and recording frequencies match the overall system response to a rapid change in the value of concentrations at the sample probe. Gas analyzer systems shall be optimized such that their overall response to a rapid change in concentration is updated and recorded at an appropriate frequency to prevent loss of information. This test also verifies that continuous gas analyzer systems meet a minimum response time.

The system settings for the response time evaluation shall be exactly the same as during measurement of the test run (i.e. pressure, flow rates, filter settings on the analyzers and all other response time influences). The response time determination shall be done with gas switching directly at the inlet of the sample probe. The devices for gas switching shall have a specification to perform the switching in less than 0,1 s. The gases used for the test shall cause a concentration change of at least 60 % full scale (FS).

The concentration trace of each single gas component shall be recorded.

8.1.5.3. System requirements

- (a) The system response time shall be ≤ 10 s with a rise time of ≤ 5 s for all measured components (CO, NO_x, 2 and HC) and all ranges used.

All data (concentration, fuel and air flows) have to be shifted by their measured response times before performing the emission calculations given in Annex VII.

- (b) To demonstrate acceptable updating and recording with respect to the system's overall response, the system shall meet one of the following criteria:

- (i) The product of the mean rise time and the frequency at which the system records an updated concentration shall be at least 5. In any case the mean rise time shall be no more than 10 s;
- (ii) The frequency at which the system records the concentration shall be at least 2 Hz (see also Table 6.7.).

8.1.5.4. Procedure

The following procedure shall be used to verify the response of each continuous gas analyzer system:

- (a) The analyzer system manufacturer's start-up and operating instructions for the instrument setup shall be followed. The measurement system shall be adjusted as needed to optimize performance. This verification shall be run with the analyzer operating in the same manner as used for emission testing. If the analyzer shares its sampling system with other analyzers, and if gas flow to the other analyzers will affect the system response time, then the other analyzers shall be started up and operated while running this verification test. This verification test may be run on multiple analyzers sharing the same sampling system at the same time. If analogue or real-time digital filters are used during emission testing, those filters shall be operated in the same manner during this verification;
- (b) For equipment used to validate system response time, minimal gas transfer line lengths between all connections are recommended to be used, a zero-air source shall be connected to one inlet of a fast-acting 3-way valve (2 inlets, 1 outlet) in order to control the flow of zero and blended span gases to the sample system's probe inlet or a tee near the outlet of the probe. Normally the gas flow rate is higher than the probe sample flow rate and the excess is overflowed out the inlet of the probe. If the gas flow rate is lower than the probe flow rate, the gas concentrations shall be adjusted to account for the dilution from ambient air drawn into the probe. Binary or multi-gas span gases may be used. A gas blending or mixing device may be used to blend span gases. A gas blending or mixing device is recommended when blending span gases diluted in N₂ with span gases diluted in air;

Using a gas divider, an NO-CO-CO₂-C₃H₈-CH₄ (balance N₂) span gas shall be equally blended with a span gas of NO₂, balance purified synthetic air. Standard binary span gases may be also be used, where applicable, in place of blended NO-CO-CO₂-C₃H₈-CH₄, balance N₂ span gas; in this case separate response tests shall be run for each analyzer. The gas divider outlet shall be connected to the other inlet of the 3-way valve. The valve outlet shall be connected to an overflow at the gas analyzer system's probe or to an overflow fitting between the probe and transfer line to all the analyzers being verified. A setup that avoids pressure pulsations due to stopping the flow through the gas blending device shall be used. Any of these gas constituents if they are not relevant to the analyzers for this

verification shall be omitted. Alternatively the use of gas bottles with single gases and a separate measurement of response times is allowed;

- (c) Data collection shall be done as follows:
- (i) The valve shall be switched to start the flow of zero gas;
 - (ii) Stabilization shall be allowed for, accounting for transport delays and the slowest analyzer's full response;
 - (iii) Data recording shall be started at the frequency used during emission testing. Each recorded value shall be a unique updated concentration measured by the analyzer; interpolation or filtering may not be used to alter recorded values;
 - (iv) The valve shall be switched to allow the blended span gases to flow to the analyzers. This time shall be recorded as t_0 ;
 - (v) Transport delays and the slowest analyzer's full response shall be allowed for;
 - (vi) The flow shall be switched to allow zero gas to flow to the analyzer. This time shall be recorded as t_{100} ;
 - (vii) Transport delays and the slowest analyzer's full response shall be allowed for;
 - (viii) The steps in paragraphs (c)(iv) to (vii) of this point shall be repeated to record seven full cycles, ending with zero gas flowing to the analyzers;
 - (ix) Recording shall be stopped.

8.1.5.5. Performance evaluation

The data from point 8.1.5.4.(c) shall be used to calculate the mean rise time for each of the analyzers.

- (a) If it is chosen to demonstrate compliance with point 8.1.5.3.(b)(i) the following procedure has to be applied: The rise times (in s) shall be multiplied by their respective recording frequencies in Hertz (1/s). The value for each result shall be at least 5. If the value is less than 5, the recording frequency shall be increased or the flows adjusted or the design of the sampling system shall be changed to increase the rise time as needed. Also digital filters may be configured to increase rise time;
- (b) If it is chosen to demonstrate compliance with point 8.1.5.3.(b)(ii), the demonstration of compliance with the requirements of point 8.1.5.3.(b)(ii) is sufficient.

8.1.6. Response time verification for compensation type analysers

8.1.6.1. Scope and frequency

This verification shall be performed to determine a continuous gas analyzer's response, where one analyzer's response is compensated by another's to quantify a gaseous emission. For this check water vapour shall be considered to be a gaseous constituent. This verification is required for continuous gas analyzers used for transient (NRTC and LSI-NRTC) test cycles or RMC. This verification is not needed for batch gas analyzers or for continuous gas analyzers that are used only for testing with a discrete-mode NRSC. This verification does not apply to correction for water removed from the sample done in post-processing. This verification shall be performed after initial installation (i.e. test cell commissioning). After major maintenance, point 8.1.5. may be used to verify uniform response provided that any replaced components have gone through a humidified uniform response verification at some point.

8.1.6.2. Measurement principles

This procedure verifies the time-alignment and uniform response of continuously combined gas measurements. For this procedure, it is necessary to ensure that all compensation algorithms and humidity corrections are turned on.

8.1.6.3. System requirements

The general response time and rise time requirement set out in point 8.1.5.3.(a) is also valid for compensation type analysers. Additionally, if the recording frequency is different than the update frequency of the continuously combined/compensated signal, the lower of these two frequencies shall be used for the verification required by point 8.1.5.3.(b)(i).

8.1.6.4. Procedure

All procedures set out in point 8.1.5.4.(a) to (c) shall be used. Additionally also the response and rise time of water vapour has to be measured, if a compensation algorithm based on measured water vapour is used. In this case at least one of the used calibration gases (but not NO₂) has to be humidified as follows:

If the system does not use a sample dryer to remove water from the sample gas, the span gas shall be humidified by flowing the gas mixture through a sealed vessel that humidifies the gas to the highest sample dew point that is estimated during emission sampling by bubbling it through distilled water. If the system uses a sample dryer during testing that has passed the sample dryer verification check, the humidified gas mixture may be introduced downstream of the sample dryer by bubbling it through distilled water in a sealed vessel at 298 ± 10 K (25 ± 10 °C), or a temperature greater than the dew point. In all cases, downstream of the vessel, the humidified gas shall be maintained at a temperature of at least 5 K (5 °C) above its local dew point in the line. Note that it is possible to omit any of these gas constituents if they are not relevant to the analyzers for this verification. If any of the gas constituents are not susceptible to

water compensation, the response check for these analyzers may be performed without humidification.

8.1.7. Measurement of engine parameters and ambient conditions

The engine manufacturer shall apply internal quality procedures traceable to recognised national or international standards. Otherwise the following procedures apply.

8.1.7.1. Torque calibration

8.1.7.1.1. Scope and frequency

All torque-measurement systems including dynamometer torque measurement transducers and systems shall be calibrated upon initial installation and after major maintenance using, among others, reference force or lever-arm length coupled with dead weight. Good engineering judgment shall be used to repeat the calibration. The torque transducer manufacturer's instructions shall be followed for linearizing the torque sensor's output. Other calibration methods are permitted.

8.1.7.1.2. Dead-weight calibration

This technique applies a known force by hanging known weights at a known distance along a lever arm. It shall be made sure that the weights' lever arm is perpendicular to gravity (i.e., horizontal) and perpendicular to the dynamometer's rotational axis. At least six calibration-weight combinations shall be applied for each applicable torque-measuring range, spacing the weight quantities about equally over the range. The dynamometer shall be oscillated or rotated during calibration to reduce frictional static hysteresis. Each weight's force shall be determined by multiplying its internationally-traceable mass by the local acceleration of Earth's gravity.

8.1.7.1.3. Strain gage or proving ring calibration

This technique applies force either by hanging weights on a lever arm (these weights and their lever arm length are not used as part of the reference torque determination) or by operating the dynamometer at different torques. At least six force combinations shall be applied for each applicable torque-measuring range, spacing the force quantities about equally over the range. The dynamometer shall be oscillated or rotated during calibration to reduce frictional static hysteresis. In this case, the reference torque is determined by multiplying the force output from the reference meter (such as a strain gage or proving ring) by its effective lever-arm length, which is measured from the point where the force measurement is made to the dynamometer's rotational axis. It shall be made sure that this length is measured perpendicular to the reference meter's measurement axis and perpendicular to the dynamometer's rotational axis.

8.1.7.2. Pressure, temperature, and dew point calibration

Instruments shall be calibrated for measuring pressure, temperature, and dew point upon initial installation. The instrument manufacturer's instructions shall be followed and good engineering judgment shall be used to repeat the calibration.

For temperature measurement systems with thermocouple, RTD, or thermistor sensors, the calibration of the system shall be performed as described in point 8.1.4.4. for linearity verification.

8.1.8. Flow-related measurements

8.1.8.1. Fuel flow calibration

Fuel flow meters shall be calibrated upon initial installation. The instrument manufacturer's instructions shall be followed and good engineering judgment shall be used to repeat the calibration.

8.1.8.2. Intake air flow calibration

Intake air flow meters shall be calibrated upon initial installation. The instrument manufacturer's instructions shall be followed and good engineering judgment shall be used to repeat the calibration.

8.1.8.3. Exhaust gas flow calibration

Exhaust flow meters shall be calibrated upon initial installation. The instrument manufacturer's instructions shall be followed and good engineering judgment shall be used to repeat the calibration.

8.1.8.4. Diluted exhaust gas flow (CVS) calibration

8.1.8.4.1. Overview

- (a) This section describes how to calibrate flow meters for diluted exhaust gas constant-volume sampling (CVS) systems;
- (b) This calibration shall be performed while the flow meter is installed in its permanent position. This calibration shall be performed after any part of the flow configuration upstream or downstream of the flow meter has been changed that may affect the flow-meter calibration. This calibration shall be performed upon initial CVS installation and whenever corrective action does not resolve a failure to meet the diluted exhaust gas flow verification (*i.e.*, propane check) in point 8.1.8.5.;
- (c) A CVS flow meter shall be calibrated using a reference flow meter such as a subsonic venturi flow meter, a long-radius flow nozzle, a smooth approach orifice, a laminar flow element, a set of critical flow venturis, or an ultrasonic flow meter. A reference flow meter shall be used that reports quantities that are internationally-traceable within ± 1 % uncertainty. This reference flow meter's

response to flow shall be used as the reference value for CVS flow-meter calibration;

- (d) An upstream screen or other pressure restriction that could affect the flow ahead of the reference flow meter may not be used, unless the flow meter has been calibrated with such a pressure restriction;
- (e) The calibration sequence described under this point 8.1.8.4. refers to the molar based approach. For the corresponding sequence used in the mass based approach, see point 2.5 of Annex VII.
- (f) By the choice of the manufacturer, CFV or SSV may alternatively be removed from its permanent position for calibration as long as the following requirements are met when installed in the CVS:
 - (1) Upon installation of the CFV or SSV into the CVS, good engineering judgment shall be applied to verify that any leaks have not been introduced between the CVS inlet and the venturi.
 - (2) After ex-situ venturi calibration, all venturi flow combinations must be verified for CFVs or at minimum of 10 flow points for an SSV using the propane check as described in point 8.1.8.5.. The result of the propane check for each venturi flow point may not exceed the tolerance in point 8.1.8.5.6..
 - (3) In order to verify the ex-situ calibration for a CVS with more than a single CFV, the following verification shall be conducted:
 - (i) A constant flow device shall be used to deliver a constant flow of propane to the dilution tunnel.
 - (ii) The hydrocarbon concentrations shall be measured at a minimum of 10 separate flow rates for an SSV flow meter, or at all possible flow combinations for a CFV flow meter, while keeping the flow of propane constant.
 - (iii) The concentration of hydrocarbon background in the dilution air shall be measured at the beginning and end of this test. The average background concentration from each measurement at each flow point must be subtracted before performing the regression analysis in paragraph (iv).
 - (iv) A power regression has to be performed using all the paired values of flow rate and corrected concentration to obtain a relationship in the form of $y = a \cdot x^b$, using the concentration as the independent variable and the flow rate as the dependent variable. For each data point, the calculation of the difference between the measured flow rate and the value represented by the curve fit is required. The difference at each point must be less than $\pm 1\%$ of the appropriate regression value. The

value of b must be between $-1,005$ and $-0,995$. If the results do not meet these limits, corrective actions consistent with point 8.1.8.5.1.(a) must be taken.

8.1.8.4.2. PDP calibration

A positive-displacement pump (PDP) shall be calibrated to determine a flow-versus-PDP speed equation that accounts for flow leakage across sealing surfaces in the PDP as a function of PDP inlet pressure. Unique equation coefficients shall be determined for each speed at which the PDP is operated. A PDP flow meter shall be calibrated as follows:

- (a) The system shall be connected as shown in Figure 6.5.;
- (b) Leaks between the calibration flow meter and the PDP shall be less than 0,3 % of the total flow at the lowest calibrated flow point; for example, at the highest pressure restriction and lowest PDP-speed point;
- (c) While the PDP operates, a constant temperature at the PDP inlet shall be maintained within ± 2 % of the mean absolute inlet temperature, T_{in} ;
- (d) The PDP speed is set to the first speed point at which it is intended to calibrate;
- (e) The variable restrictor is set to its wide-open position;
- (f) The PDP is operated for at least 3 minutes to stabilize the system. Then by continuously operating the PDP, the mean values of at least 30 s of sampled data of each of the following quantities are recorded:
 - (i) The mean flow rate of the reference flow meter, \bar{q}_{Vref} ;
 - (ii) The mean temperature at the PDP inlet, T_{in} ;
 - (iii) The mean static absolute pressure at the PDP inlet, p_{in} ;
 - (iv) The mean static absolute pressure at the PDP outlet, p_{out} ;
 - (v) The mean PDP speed, n_{PDP} ;
- (g) The restrictor valve shall be incrementally closed to decrease the absolute pressure at the inlet to the PDP, p_{in} ;
- (h) The steps in paragraphs 8.1.8.4.2.(f) and (g) shall be repeated to record data at a minimum of six restrictor positions reflecting the full range of possible in-use pressures at the PDP inlet;
- (i) The PDP shall be calibrated by using the collected data and the equations set out in Annex VII;

- (j) The steps in paragraphs (f) to (i) of this point shall be repeated for each speed at which the PDP is operated;
- (k) The equations in section 3. of Annex VII (molar based approach) or section 2. of Annex VII (mass based approach) shall be used to determine the PDP flow equation for emission testing;
- (l) The calibration shall be verified by performing a CVS verification (i.e., propane check) as described in point 8.1.8.5.;
- (m) The PDP may not be used below the lowest inlet pressure tested during calibration.

8.1.8.4.3. CFV calibration

A critical-flow venturi (CFV) shall be calibrated to verify its discharge coefficient, C_d , at the lowest expected static differential pressure between the CFV inlet and outlet. A CFV flow meter shall be calibrated as follows:

- (a) The system shall be connected as shown in Figure 6.5.;
- (b) The blower shall be started downstream of the CFV;
- (c) While the CFV operates, a constant temperature at the CFV inlet shall be maintained within ± 2 % of the mean absolute inlet temperature, T_{in} ;
- (d) Leaks between the calibration flow meter and the CFV shall be less than 0,3 % of the total flow at the highest pressure restriction;
- (e) The variable restrictor shall be set to its wide-open position. In lieu of a variable restrictor the pressure downstream of the CFV may be varied by varying blower speed or by introducing a controlled leak. Note that some blowers have limitations on non-loaded conditions;
- (f) The CFV shall be operated for at least 3 minutes to stabilize the system. The CFV shall continue operating and the mean values of at least 30 s of sampled data of each of the following quantities shall be recorded:
 - (i) The mean flow rate of the reference flow meter, \bar{q}_{Vref} ;
 - (ii) Optionally, the mean dew point of the calibration air, T_{dew} . See Annex VII for permissible assumptions during emission measurements;
 - (iii) The mean temperature at the venturi inlet, T_{in} ;
 - (iv) The mean static absolute pressure at the venturi inlet, p_{in} ;

- (v) The mean static differential pressure between the CFV inlet and the CFV outlet, Δp_{CFV} ;
- (g) The restrictor valve shall be incrementally closed to decrease the absolute pressure at the inlet to the CFV, p_{in} ;
- (h) The steps in paragraphs (f) and (g) of this point shall be repeated to record mean data at a minimum of ten restrictor positions, such that the fullest practical range of Δp_{CFV} expected during testing is tested. It is not required to remove calibration components or CVS components to calibrate at the lowest possible pressure restrictions;
- (i) C_d and the highest allowable pressure ratio r shall be determined as described in Annex VII;
- (j) C_d shall be used to determine CFV flow during an emission test. The CFV shall not be used above the highest allowed r , as determined in Annex VII;
- (k) The calibration shall be verified by performing a CVS verification (*i.e.*, propane check) as described in point 8.1.8.5.;
- (l) If the CVS is configured to operate more than one CFV at a time in parallel, the CVS shall be calibrated by one of the following:
 - (i) Every combination of CFVs shall be calibrated according to this section and with Annex VII. See Annex VII for instructions on calculating flow rates for this option;
 - (ii) Each CFV shall be calibrated according to this point and Annex VII. See Annex VII for instructions on calculating flow rates for this option.

8.1.8.4.4. SSV calibration

A subsonic venturi (SSV) shall be calibrated to determine its calibration coefficient, C_d , for the expected range of inlet pressures. An SSV flow meter shall be calibrated as follows:

- (a) The system shall be connected as shown in Figure 6.5.;
- (b) The blower shall be started downstream of the SSV;
- (c) Leaks between the calibration flow meter and the SSV shall be less than 0,3 % of the total flow at the highest pressure restriction;
- (d) While the SSV operates, a constant temperature at the SSV inlet shall be maintained within ± 2 % of the mean absolute inlet temperature, T_{in} ;
- (e) The variable restrictor or variable-speed blower shall be set to a flow rate greater than the greatest flow rate expected during testing. Flow rates may not be

extrapolated beyond calibrated values, so it is recommended that it is made certain that a Reynolds number, Re , at the SSV throat at the greatest calibrated flow rate is greater than the maximum Re expected during testing;

- (f) The SSV shall be operated for at least 3 min to stabilize the system. The SSV shall continue operating and the mean of at least 30 s of sampled data of each of the following quantities shall be recorded:
 - (i) The mean flow rate of the reference flow meter, \bar{q}_{Vref} ;
 - (ii) Optionally, the mean dew point of the calibration air, T_{dew} . See Annex VII for permissible assumptions;
 - (iii) The mean temperature at the venturi inlet, T_{in} ;
 - (iv) The mean static absolute pressure at the venturi inlet, p_{in} ;
 - (v) Static differential pressure between the static pressure at the venturi inlet and the static pressure at the venturi throat, Δp_{SSV} ;
- (g) The restrictor valve shall be incrementally closed or the blower speed decreased to decrease the flow rate;
- (h) The steps in paragraphs (f) and (g) of this point shall be repeated to record data at a minimum of ten flow rates;
- (i) A functional form of C_d versus Re shall be determined by using the collected data and the equations in Annex VII;
- (j) The calibration shall be verified by performing a CVS verification (*i.e.*, propane check) as described in point 8.1.8.5. using the new C_d versus Re equation;
- (k) The SSV shall be used only between the minimum and maximum calibrated flow rates;
- (l) The equations in section 3. of Annex VII (molar based approach) or section 2. of Annex VII (mass based approach) shall be used to determine SSV flow during a test.

8.1.8.4.5. Ultrasonic calibration (reserved)

Figure 6.5.

Schematic diagrams for diluted exhaust gas flow CVS calibration

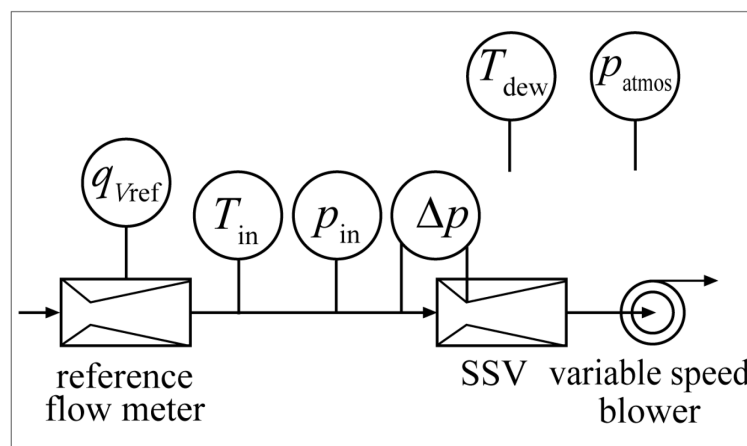
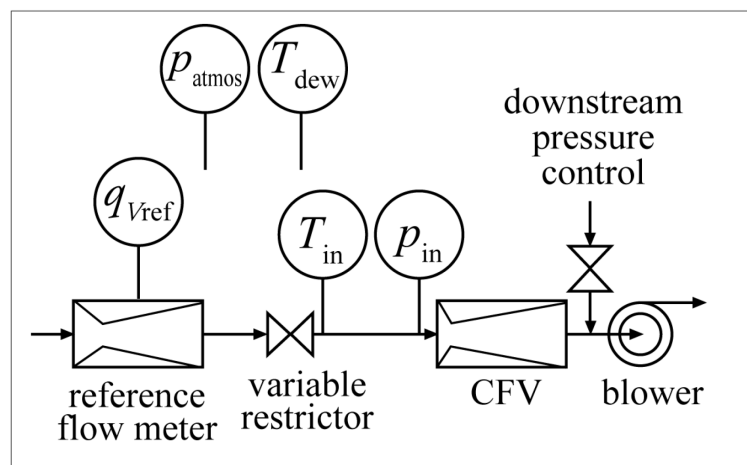
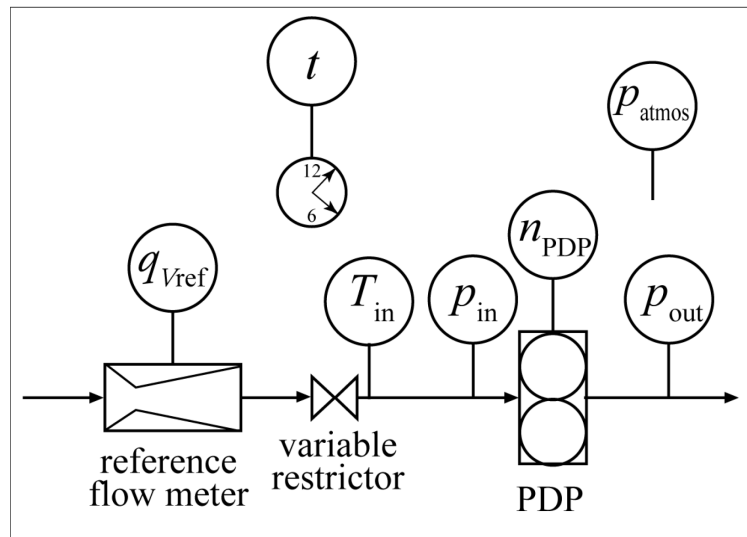

8.1.8.5. CVS and batch sampler verification (propane check)

8.1.8.5.1. Introduction

- (a) A propane check serves as a CVS verification to determine if there is a discrepancy in measured values of diluted exhaust gas flow. A propane check also serves as a batch-sampler verification to determine if there is a discrepancy in a batch sampling system that extracts a sample from a CVS, as described in paragraph (f) of this point. Using good engineering judgment and safe practices, this check may be performed using a gas other than propane, such as CO₂ or CO. A failed propane check might indicate one or more problems that may require corrective action, as follows:
- (i) Incorrect analyzer calibration. The FID analyzer shall be re-calibrated, repaired, or replaced;
 - (ii) Leak checks shall be performed on CVS tunnel, connections, fasteners, and HC sampling system according to point 8.1.8.7.;
 - (iii) The verification for poor mixing shall be performed in accordance with point 9.2.2.;
 - (iv) The hydrocarbon contamination verification in the sample system shall be performed as described in point 7.3.1.2.;
 - (v) Change in CVS calibration. An in-situ calibration of the CVS flow meter shall be performed as described in point 8.1.8.4.;
 - (vi) Other problems with the CVS or sampling verification hardware or software. The CVS system, CVS verification hardware, and software shall be inspected for discrepancies;
- (b) A propane check uses either a reference mass or a reference flow rate of C₃H₈ as a tracer gas in a CVS. If a reference flow rate is used, any non-ideal gas behaviour of C₃H₈ in the reference flow meter shall be accounted for. See section 2. of Annex VII (mass based approach) or section 3. of Annex VII (molar based approach), which describe how to calibrate and use certain flow meters. No ideal gas assumption may be used in point 8.1.8.5. and Annex VII. The propane check compares the calculated mass of injected C₃H₈ using HC measurements and CVS flow rate measurements with the reference value.

8.1.8.5.2. Method of introducing a known amount of propane into the CVS system

The total accuracy of the CVS sampling system and analytical system shall be determined by introducing a known mass of a pollutant gas into the system while it is being operated in the normal manner. The pollutant is analyzed, and the mass calculated in accordance with Annex VII. Either of the following two techniques shall be used:

- (a) Metering by means of a gravimetric technique shall be done as follows: A mass of a small cylinder filled with carbon monoxide or propane shall be determined with a precision of $\pm 0,01$ g. For about 5 to 10 minutes, the CVS system shall be operated as in a normal exhaust emissions test, while carbon monoxide or propane is injected into the system. The quantity of pure gas discharged shall be determined by means of differential weighing. A gas sample shall be analyzed with the usual equipment (sampling bag or integrating method), and the mass of the gas calculated;
- (b) Metering with a critical flow orifice shall be done as follows: A known quantity of pure gas (carbon monoxide or propane) shall be fed into the CVS system through a calibrated critical orifice. If the inlet pressure is high enough, the flow rate, which is adjusted by means of the critical flow orifice, is independent of the orifice outlet pressure (critical flow). The CVS system shall be operated as in a normal exhaust emissions test for about 5 to 10 minutes. A gas sample shall be analyzed with the usual equipment (sampling bag or integrating method), and the mass of the gas calculated.

8.1.8.5.3. Preparation of the propane check

The propane check shall be prepared as follows:

- (a) If a reference mass of C_3H_8 is used instead of a reference flow rate, a cylinder charged with C_3H_8 shall be obtained. The reference cylinder's mass of C_3H_8 shall be determined within $\pm 0,5$ % of the amount of C_3H_8 that is expected to be used;
- (b) Appropriate flow rates shall be selected for the CVS and C_3H_8 ;
- (c) A C_3H_8 injection port shall be selected in the CVS. The port location shall be selected to be as close as practical to the location where engine exhaust system is introduced into the CVS. The C_3H_8 cylinder shall be connected to the injection system;
- (d) The CVS shall be operated and stabilized;
- (e) Any heat exchangers in the sampling system shall be pre-heated or pre-cooled;
- (f) Heated and cooled components such as sample lines, filters, chillers, and pumps shall be allowed to stabilize at operating temperature;
- (g) If applicable, a vacuum side leak verification of the HC sampling system shall be performed as described in point 8.1.8.7..

8.1.8.5.4. Preparation of the HC sampling system for the propane check

Vacuum side leak check verification of the HC sampling system may be performed according to paragraph (g) of this point. If this procedure is used, the HC contamination procedure in point 7.3.1.2. may be used. If the vacuum side leak check is not performed

according to paragraph (g), then the HC sampling system shall be zeroed, spanned, and verified for contamination, as follows:

- (a) The lowest HC analyzer range that can measure the C_3H_8 concentration expected for the CVS and C_3H_8 flow rates shall be selected;
- (b) The HC analyzer shall be zeroed using zero air introduced at the analyzer port;
- (c) The HC analyzer shall be spanned using C_3H_8 span gas introduced at the analyzer port;
- (d) Zero air shall be overflowed at the HC probe or into a fitting between the HC probe and the transfer line;
- (e) The stable HC concentration of the HC sampling system shall be measured as overflow zero air flows. For batch HC measurement, the batch container (such as a bag) shall be filled and the HC overflow concentration measured;
- (f) If the overflow HC concentration exceeds $2 \mu\text{mol/mol}$, the procedure may not be advanced until contamination is eliminated. The source of the contamination shall be determined and corrective action taken, such as cleaning the system or replacing contaminated portions;
- (g) When the overflow HC concentration does not exceed $2 \mu\text{mol/mol}$, this value shall be recorded as $x_{HC\text{init}}$ and it shall be used to correct for HC contamination as described in section 2. of Annex VII (mass based approach) or section 3. of Annex VII (molar based approach).

8.1.8.5.5. Propane check performance

- (a) The propane check shall be performed as follows:
 - (i) For batch HC sampling, clean storage media, such as evacuated bags shall be connected;
 - (ii) HC measurement instruments shall be operated according to the instrument manufacturer's instructions;
 - (iii) If correction for dilution air background concentrations of HC is foreseen, background HC in the dilution air shall be measured and recorded;
 - (iv) Any integrating devices shall be zeroed;
 - (v) Sampling shall begin and any flow integrators shall be started;
 - (vi) C_3H_8 shall be released at the rate selected. If a reference flow rate of C_3H_8 is used, the integration of this flow rate shall be started;

- (vii) C_3H_8 shall be continued to be released until at least enough C_3H_8 has been released to ensure accurate quantification of the reference C_3H_8 and the measured C_3H_8 ;
 - (viii) The C_3H_8 cylinder shall be shut off and sampling shall continue until it has been accounted for time delays due to sample transport and analyzer response;
 - (ix) Sampling shall be stopped and any integrators shall be stopped;
- (b) In case the metering with a critical flow orifice is used, the following procedure may be used for the propane check as the alternative method of point 8.1.8.5.5.(a);
- (i) For batch HC sampling, clean storage media, such as evacuated bags shall be connected;
 - (ii) HC measurement instruments shall be operated according to the instrument manufacturer's instructions;
 - (iii) If correction for dilution air background concentrations of HC is foreseen, background HC in the dilution air shall be measured and recorded;
 - (iv) Any integrating devices shall be zeroed;
 - (v) The contents of the C_3H_8 reference cylinder shall be released at the rate selected;
 - (vi) Sampling shall begin, and any flow integrators started after confirming that HC concentration is to be stable;
 - (vii) The cylinder's contents shall be continued to be released until at least enough C_3H_8 has been released to ensure accurate quantification of the reference C_3H_8 and the measured C_3H_8 ;
 - (viii) Any integrators shall be stopped;
 - (ix) The C_3H_8 reference cylinder shall be shut off.

8.1.8.5.6. Evaluation of the propane check

Post-test procedure shall be performed as follows:

- (a) If batch sampling has been used, batch samples shall be analyzed as soon as practical;
- (b) After analyzing HC, contamination and background shall be corrected for;

- (c) Total C₃H₈ mass based on the CVS and HC data shall be calculated as described in Annex VII, using the molar mass of C₃H₈, $M_{C_3H_8}$, instead of the effective molar mass of HC, M_{HC} ;
- (d) If a reference mass (gravimetric technique) is used, the cylinder's propane mass shall be determined within $\pm 0,5 \%$ and the C₃H₈ reference mass shall be determined by subtracting the empty cylinder propane mass from the full cylinder propane mass. If a critical flow orifice (metering with a critical flow orifice) is used, the propane mass shall be determined as flow rate multiplied by the test time;
- (e) The reference C₃H₈ mass shall be subtracted from the calculated mass. If this difference is within $\pm 3,0 \%$ of the reference mass, the CVS passes this verification.

8.1.8.5.7. PM secondary dilution system verification

When the propane check is to be repeated to verify the PM secondary dilution system, the following procedure from (a) to (d) shall be used for this verification:

- (a) The HC sampling system shall be configured to extract a sample near the location of the batch sampler's storage media (such as a PM filter). If the absolute pressure at this location is too low to extract an HC sample, HC may be sampled from the batch sampler pump's exhaust. Caution shall be used when sampling from pump's exhaust because an otherwise acceptable pump leak downstream of a batch sampler flow meter will cause a false failure of the propane check;
- (b) The propane check shall be repeated as described in this point, but HC shall be sampled from the batch sampler;
- (c) C₃H₈ mass shall be calculated, taking into account any secondary dilution from the batch sampler;
- (d) The reference C₃H₈ mass shall be subtracted from the calculated mass. If this difference is within $\pm 5 \%$ of the reference mass, the batch sampler passes this verification. If not, corrective action shall be taken.

8.1.8.5.8. Sample dryer verification

If a humidity sensor for continuous monitoring of dew point at the sample dryer outlet is used this check does not apply, as long as it is ensured that the dryer outlet humidity is below the minimum values used for quench, interference, and compensation checks.

- (a) If a sample dryer is used as allowed in point 9.3.2.3.1. to remove water from the sample gas, the performance shall be verified upon installation, after major maintenance, for thermal chillers. For osmotic membrane dryers, the performance shall be verified upon installation, after major maintenance, and within 35 days of testing;

- (b) Water can inhibit an analyzer's ability to properly measure the exhaust component of interest and thus is sometimes removed before the sample gas reaches the analyzer. For example water can negatively interfere with a CLD's NO_x response through collisional quenching and can positively interfere with an NDIR analyzer by causing a response similar to CO;
- (c) The sample dryer shall meet the specifications as determined in point 9.3.2.3.1. for dew point, T_{dew} , and absolute pressure, p_{total} , downstream of the osmotic-membrane dryer or thermal chiller;
- (d) The following sample dryer verification procedure method shall be used to determine sample dryer performance, or good engineering judgment shall be used to develop a different protocol:
 - (i) polytetrafluoroethylene ("PTFE") or stainless steel tubing shall be used to make necessary connections;
 - (ii) N₂ or purified air shall be humidified by bubbling it through distilled water in a sealed vessel that humidifies the gas to the highest sample dew point that is estimated during emission sampling;
 - (iii) The humidified gas shall be introduced upstream of the sample dryer;
 - (iv) The humidified gas temperature downstream of the vessel shall be maintained at least 5 °C above its dew point;
 - (v) The humidified gas dew point, T_{dew} , and pressure, p_{total} , shall be measured as close as possible to the inlet of the sample dryer to verify that the dew point is the highest that was estimated during emission sampling;
 - (vi) The humidified gas dew point, T_{dew} , and pressure, p_{total} , shall be measured as close as possible to the outlet of the sample dryer;
 - (vii) The sample dryer meets the verification if the result of point (d)(vi) of this section is less than the dew point corresponding to the sample dryer specifications as determined in point 9.3.2.3.1. plus 2 °C or if the mol fraction from (d)(vi) is less than the corresponding sample dryer specifications plus 0,002 mol/mol or 0,2 volume %. Note for this verification, sample dew point is expressed in absolute temperature, Kelvin.

8.1.8.6. Periodic calibration of the partial flow PM and associated raw exhaust gas measurement systems

8.1.8.6.1. Specifications for differential flow measurement

For partial flow dilution systems to extract a proportional raw exhaust gas sample, the accuracy of the sample flow q_{mp} is of special concern, if not measured directly, but determined by differential flow measurement as set out in equation (6-20):

$$q_{mp} = q_{mdew} - q_{mdw} \quad (6-20)$$

Where:

q_{mp} is the sample mass flow rate of exhaust gas into partial flow dilution system

q_{mdw} is the dilution air mass flow rate (on wet basis)

q_{mdew} is the diluted exhaust gas mass flow rate on wet basis

In this case, the maximum error of the difference shall be such that the accuracy of q_{mp} is within $\pm 5\%$ when the dilution ratio is less than 15. It can be calculated by taking root-mean-square of the errors of each instrument.

Acceptable accuracies of q_{mp} can be obtained by either of the following methods:

- (a) The absolute accuracies of q_{mdew} and q_{mdw} are $\pm 0,2\%$ which guarantees an accuracy of q_{mp} of $\leq 5\%$ at a dilution ratio of 15. However, greater errors will occur at higher dilution ratios;
- (b) Calibration of q_{mdw} relative to q_{mdew} is carried out such that the same accuracies for q_{mp} as in (a) are obtained. For details see point 8.1.8.6.2.;
- (c) The accuracy of q_{mp} is determined indirectly from the accuracy of the dilution ratio as determined by a tracer gas, e.g. CO_2 . Accuracies equivalent to method (a) for q_{mp} are required;
- (d) The absolute accuracy of q_{mdew} and q_{mdw} is within $\pm 2\%$ of full scale, the maximum error of the difference between q_{mdew} and q_{mdw} is within $0,2\%$ and the linearity error is within $\pm 0,2\%$ of the highest q_{mdew} observed during the test.

8.1.8.6.2. Calibration of differential flow measurement

The partial flow dilution system to extract a proportional raw exhaust gas sample shall be periodically calibrated with an accurate flow meter traceable to international and/or national standards. The flow meter or the flow measurement instrumentation shall be calibrated in one of the following procedures, such that the probe flow q_{mp} into the tunnel shall fulfil the accuracy requirements of point 8.1.8.6.1..

- (a) The flow meter for q_{mdw} shall be connected in series to the flow meter for q_{mdew} , the difference between the two flow meters shall be calibrated for at least 5 set points with flow values equally spaced between the lowest q_{mdw} value used during the test and the value of q_{mdew} used during the test. The dilution tunnel may be bypassed;

- (b) A calibrated flow device shall be connected in series to the flowmeter for q_{mdew} and the accuracy shall be checked for the value used for the test. The calibrated flow device shall be connected in series to the flow meter for q_{mdw} , and the accuracy shall be checked for at least 5 settings corresponding to dilution ratio between 3 and 15, relative to q_{mdew} used during the test;
- (c) The transfer line TL (see Figure 6.7.) shall be disconnected from the exhaust system and a calibrated flow measuring device with a suitable range to measure q_{mp} shall be connected to the transfer line. q_{mdew} shall be set to the value used during the test, and q_{mdw} shall be sequentially set to at least 5 values corresponding to dilution ratios between 3 and 15. Alternatively, a special calibration flow path may be provided, in which the tunnel is bypassed, but the total and dilution air flow is passed through the corresponding meters as in the actual test;
- (d) A tracer gas, shall be fed into the exhaust system transfer line TL. This tracer gas may be a component of the exhaust gas, like CO₂ or NO_x. After dilution in the tunnel the tracer gas component shall be measured. This shall be carried out for 5 dilution ratios between 3 and 15. The accuracy of the sample flow shall be determined from the dilution ratio r_d by means of equation (6-21):

$$q_{mp} = q_{mdew} / r_d \quad (6-21)$$

The accuracies of the gas analyzers shall be taken into account to guarantee the accuracy of q_{mp} .

8.1.8.6.3. Special requirements for differential flow measurement

A carbon flow check using actual exhaust gas is strongly recommended for detecting measurement and control problems and verifying the proper operation of the partial flow system. The carbon flow check should be run at least each time a new engine is installed, or something significant is changed in the test cell configuration.

The engine shall be operated at peak torque load and speed or any other steady state mode that produces 5 % or more of CO₂. The partial flow sampling system shall be operated with a dilution factor of about 15 to 1.

If a carbon flow check is conducted, Appendix 2 of Annex VII shall be applied. The carbon flow rates shall be calculated according to equations of Appendix 2 of Annex VII. All carbon flow rates shall agree to within 5 %.

8.1.8.6.3.1. Pre-test check

A pre-test check shall be performed within 2 hours before the test run in the following way.

The accuracy of the flow meters shall be checked by the same method as used for calibration (see point 8.1.8.6.2.) for at least two points, including flow values of q_{mdw} that correspond to dilution ratios between 5 and 15 for the q_{mdew} value used during the test.

If it can be demonstrated by records of the calibration procedure under point 8.1.8.6.2. that the flow meter calibration is stable over a longer period of time, the pre-test check may be omitted.

8.1.8.6.3.2. Determination of the transformation time

The system settings for the transformation time evaluation shall be the same as during measurement of the test run. The transformation time, as defined in point 2.4. of Appendix 5 to this Annex and in figure 6-11, shall be determined by the following method:

An independent reference flowmeter with a measurement range appropriate for the probe flow shall be put in series with and closely coupled to the probe. This flowmeter shall have a transformation time of less than 100 ms for the flow step size used in the response time measurement, with flow pressure restriction sufficiently low as to not affect the dynamic performance of the partial flow dilution system according to good engineering judgment. A step change shall be introduced to the exhaust gas flow (or air flow if exhaust gas flow is calculated) input of the partial flow dilution system, from a low flow to at least 90 % of full scale. The trigger for the step change shall be the same one used to start the look-ahead control in actual testing. The exhaust gas flow step stimulus and the flowmeter response shall be recorded at a sample rate of at least 10 Hz.

From this data, the transformation time shall be determined for the partial flow dilution system, which is the time from the initiation of the step stimulus to the 50 % point of the flowmeter response. In a similar manner, the transformation times of the q_{mp} signal (i.e. sample flow of exhaust gas into partial flow dilution system) and of the $q_{mew,i}$ signal (i.e. the exhaust gas mass flow rate on wet basis supplied by the exhaust flow meter) shall be determined. These signals are used in the regression checks performed after each test (see point 8.2.1.2.).

The calculation shall be repeated for at least 5 rise and fall stimuli, and the results shall be averaged. The internal transformation time (<100 ms) of the reference flowmeter shall be subtracted from this value. Where look-ahead control is required, the look-ahead value of the partial flow dilution system shall be applied in accordance with point 8.2.1.2..

8.1.8.7. Vacuum-side leak verification

8.1.8.7.1. Scope and frequency

Upon initial sampling system installation, after major maintenance such as pre-filter changes, and within 8 hours prior to each duty-cycle sequence, it shall be verified that there are no significant vacuum-side leaks using one of the leak tests described in this section. This verification does not apply to any full-flow portion of a CVS dilution system.

8.1.8.7.2. Measurement principles

A leak may be detected either by measuring a small amount of flow when there shall be zero flow, by detecting the dilution of a known concentration of span gas when it flows through the vacuum side of a sampling system or by measuring the pressure increase of an evacuated system.

8.1.8.7.3. Low-flow leak test

A sampling system shall be tested for low-flow leaks as follows:

- (a) The probe end of the system shall be sealed by taking one of the following steps:
 - (i) The end of the sample probe shall be capped or plugged;
 - (ii) The transfer line shall be disconnected at the probe and the transfer line capped or plugged;
 - (iii) A leak-tight valve in-line between a probe and transfer line shall be closed;
- (b) All vacuum pumps shall be operated. After stabilizing, it shall be verified that the flow through the vacuum-side of the sampling system is less than 0,5 % of the system's normal in-use flow rate. Typical analyzer and bypass flows may be estimated as an approximation of the system's normal in-use flow rate.

8.1.8.7.4. Dilution-of-span-gas leak test

Any gas analyzer may be used for this test. If a FID is used for this test, any HC contamination in the sampling system shall be corrected in accordance with sections 2. or 3. of Annex VII on HC determination. Misleading results shall be avoided by using only analyzers that have a repeatability of 0,5 % or better at the span gas concentration used for this test. The vacuum side leak check shall be performed as follows:

- (a) A gas analyzer shall be prepared as it would be for emission testing;
- (b) Span gas shall be supplied to the analyzer port and it shall be verified that the span gas concentration is measured within its expected measurement accuracy and repeatability;
- (c) Overflow span gas shall be routed to one of the following locations in the sampling system:
 - (i) The end of the sample probe;

- (ii) The transfer line shall be disconnected at the probe connection, and the span gas overflowed at the open end of the transfer line;
- (iii) A three-way valve installed in-line between a probe and its transfer line;
- (d) It shall be verified that the measured overflow span gas concentration is within $\pm 0,5$ % of the span gas concentration. A measured value lower than expected indicates a leak, but a value higher than expected may indicate a problem with the span gas or the analyzer itself. A measured value higher than expected does not indicate a leak.

8.1.8.7.5. Vacuum-decay leak test

To perform this test a vacuum shall be applied to the vacuum-side volume of the sampling system and the leak rate of the system shall be observed as a decay in the applied vacuum. To perform this test the vacuum-side volume of the sampling system shall be known to within ± 10 % of its true volume. For this test measurement instruments that meet the specifications of points 8.1. and 9.4. shall also be used.

A vacuum-decay leak test shall be performed as follows:

- (a) The probe end of the system shall be sealed as close to the probe opening as possible by taking one of the following steps:
 - (i) The end of the sample probe shall be capped or plugged;
 - (ii) The transfer line at the probe shall be disconnected and the transfer line capped or plugged;
 - (iii) A leak-tight valve in-line between a probe and transfer line shall be closed;
- (b) All vacuum pumps shall be operated. A vacuum shall be drawn that is representative of normal operating conditions. In the case of sample bags, it is recommend that the normal sample bag pump-down procedure be repeated twice to minimize any trapped volumes;
- (c) The sample pumps shall be turned off and the system sealed. The absolute pressure of the trapped gas and optionally the system absolute temperature shall be measured and recorded. Sufficient time shall be allowed for any transients to settle and long enough for a leak at 0,5 % to have caused a pressure change of at least 10 times the resolution of the pressure transducer. The pressure and optionally temperature shall be recorded once again;
- (d) The leak flow rate based on an assumed value of zero for pumped-down bag volumes and based on known values for the sample system volume, the initial and final pressures, optional temperatures, and elapsed time shall be calculated. It shall be verified that the vacuum-decay leak flow rate is less than 0,5 % of the system's normal in-use flow rate by means of equation (6-22):

$$q_{V\text{leak}} = \frac{V_{\text{vac}} \left(\frac{p_2}{T_2} - \frac{p_1}{T_1} \right)}{R (t_2 - t_1)} \quad (6-22)$$

Where:

$q_{V\text{leak}}$	is the vacuum-decay leak rate, mol/s
V_{vac}	is the geometric volume of the vacuum-side of the sampling system, m ³
R	is the molar gas constant, J/(mol·K)
p_2	is the vacuum-side absolute pressure at time t_2 , Pa
T_2	is the vacuum-side absolute temperature at time t_2 , K
p_1	is the vacuum-side absolute pressure at time t_1 , Pa
T_1	is the vacuum-side absolute temperature at time t_1 , K
t_2	is the time at completion of vacuum-decay leak verification test, s
t_1	is the time at start of vacuum-decay leak verification test, s

8.1.9. CO and CO₂ measurements

8.1.9.1. H₂O interference verification for CO₂ NDIR analyzers

8.1.9.1.1. Scope and frequency

If CO₂ is measured using an NDIR analyzer, the amount of H₂O interference shall be verified after initial analyzer installation and after major maintenance.

8.1.9.1.2. Measurement principles

H₂O can interfere with an NDIR analyzer's response to CO₂. If the NDIR analyzer uses compensation algorithms that utilize measurements of other gases to meet this interference verification, simultaneously these other measurements shall be conducted to test the compensation algorithms during the analyzer interference verification.

8.1.9.1.3. System requirements

A CO₂ NDIR analyzer shall have an H₂O interference that is within (0,0 ± 0,4) mmol/mol (of the expected mean CO₂ concentration).

8.1.9.1.4. Procedure

The interference verification shall be performed as follows:

- (a) The CO₂ NDIR analyzer shall be started, operated, zeroed, and spanned as it would be before an emission test;
- (b) A humidified test gas shall be created by bubbling zero air that meets the specifications in point 9.5.1. through distilled water in a sealed vessel. If the sample is not passed through a dryer, control the vessel temperature to generate an H₂O level at least as high as the maximum expected during testing. If the sample is passed through a dryer during testing, control the vessel temperature to generate an H₂O level at least as high as the level required in point 9.3.2.3.1.;
- (c) The humidified test gas temperature shall be maintained at least 5 °K above its dew point downstream of the vessel;
- (d) The humidified test gas shall be introduced into the sampling system. The humidified test gas may be introduced downstream of any sample dryer, if one is used during testing;
- (e) The water mole fraction, $x_{\text{H}_2\text{O}}$, of the humidified test gas shall be measured, as close as possible to the inlet of the analyzer. For example, dew point, T_{dew} , and absolute pressure p_{total} , shall be measured to calculate $x_{\text{H}_2\text{O}}$;
- (f) Good engineering judgment shall be used to prevent condensation in the transfer lines, fittings, or valves from the point where $x_{\text{H}_2\text{O}}$ is measured to the analyzer;
- (g) Time shall be allowed for the analyzer response to stabilize. Stabilization time shall include time to purge the transfer line and to account for analyzer response;
- (h) While the analyzer measures the sample's concentration, 30 s of sampled data shall be recorded. The arithmetic mean of this data shall be calculated. The analyzer meets the interference verification if this value is within $(0,0 \pm 0,4)$ mmol/mol

8.1.9.2. H₂O and CO₂ interference verification for CO NDIR analyzers

8.1.9.2.1. Scope and frequency

If CO is measured using an NDIR analyzer, the amount of H₂O and CO₂ interference shall be verified after initial analyzer installation and after major maintenance.

8.1.9.2.2. Measurement principles

H₂O and CO₂ can positively interfere with an NDIR analyzer by causing a response similar to CO. If the NDIR analyzer uses compensation algorithms that utilize measurements of other gases to meet this interference verification, simultaneously these other measurements shall be conducted to test the compensation algorithms during the analyzer interference verification.

8.1.9.2.3. System requirements

A CO NDIR analyzer shall have combined H₂O and CO₂ interference that is within ± 2 % of the expected mean concentration of CO.

8.1.9.2.4. Procedure

The interference verification shall be performed as follows:

- (a) The CO NDIR analyzer shall be started, operated, zeroed, and spanned as it would be before an emission test;
- (b) A humidified CO₂ test gas shall be created by bubbling a CO₂ span gas through distilled water in a sealed vessel. If the sample is not passed through a dryer, the vessel temperature shall be controlled to generate an H₂O level at least as high as the maximum expected during testing. If the sample is passed through a dryer during testing, the vessel temperature shall be controlled to generate an H₂O level at least as high as the level required in point 9.3.2.3.1.1.. A CO₂ span gas concentration shall be used at least as high as the maximum expected during testing;
- (c) The humidified CO₂ test gas shall be introduced into the sampling system. The humidified CO₂ test gas may be introduced downstream of any sample dryer, if one is used during testing;
- (d) The water mole fraction, $x_{\text{H}_2\text{O}}$, of the humidified test gas shall be measured, as close as possible to the inlet of the analyzer. For example, dew point, T_{dew} , and absolute pressure p_{total} , shall be measured to calculate $x_{\text{H}_2\text{O}}$;
- (e) Good engineering judgment shall be used to prevent condensation in the transfer lines, fittings, or valves from the point where $x_{\text{H}_2\text{O}}$ is measured to the analyzer;
- (f) Time shall be allowed for the analyzer response to stabilize;
- (g) While the analyzer measures the sample's concentration, its output shall be recorded for 30 s. The arithmetic mean of this data shall be calculated;
- (h) The analyzer meets the interference verification if the result of paragraph (g) of this point meets the tolerance in point 8.1.9.2.3.;
- (i) Interference procedures for CO₂ and H₂O may be also run separately. If the CO₂ and H₂O levels used are higher than the maximum levels expected during testing, each observed interference value shall be scaled down by multiplying the observed interference by the ratio of the maximum expected concentration value to the actual value used during this procedure. Separate interference procedures concentrations of H₂O (down to 0,025 mol/mol H₂O content) that are lower than the maximum levels expected during testing may be run, but the observed H₂O interference shall be scaled up by multiplying the observed interference by the ratio of the maximum expected H₂O concentration value to the actual value used

during this procedure. The sum of the two scaled interference values shall meet the tolerance in point 8.1.9.2.3..

8.1.10. Hydrocarbon measurements

8.1.10.1. FID optimization and verification

8.1.10.1.1. Scope and frequency

For all FID analyzers, the FID shall be calibrated upon initial installation. The calibration shall be repeated as needed using good engineering judgment. The following steps shall be performed for a FID that measures HC:

- (a) A FID's response to various hydrocarbons shall be optimized after initial analyzer installation and after major maintenance. FID response to propylene and toluene shall be between 0,9 and 1,1 relative to propane;
- (b) A FID's methane (CH₄) response factor shall be determined after initial analyzer installation and after major maintenance as described in point 8.1.10.1.4.;
- (c) Methane (CH₄) response shall be verified within 185 days before testing.

8.1.10.1.2. Calibration

Good engineering judgment shall be used to develop a calibration procedure, such as one based on the FID-analyzer manufacturer's instructions and recommended frequency for calibrating the FID. The FID shall be calibrated using C₃H₈ calibration gases that meet the specifications of point 9.5.1. It shall be calibrated on a carbon number basis of one (C₁).

8.1.10.1.3. HC FID response optimization

This procedure is only for FID analyzers that measure HC.

- (a) Instrument manufacturer requirements and good engineering judgment shall be used for initial instrument start-up and basic operating adjustment using FID fuel and zero air. Heated FIDs shall be within their required operating temperature ranges. FID response shall be optimized to meet the requirement of the hydrocarbon response factors and the oxygen interference check according to points 8.1.10.1.1.(a) and 8.1.10.2. at the most common analyzer range expected during emission testing. Higher analyzer range may be used according to the instrument manufacturer's recommendation and good engineering judgment in order to optimize FID accurately, if the common analyzer range is lower than the minimum range for the optimization specified by the instrument manufacturer;
- (b) Heated FIDs shall be within their required operating temperature ranges. FID response shall be optimized at the most common analyzer range expected during

emission testing. With the fuel and airflow rates set at the manufacturer's recommendations, a span gas shall be introduced to the analyzer;

- (c) The following step from (i) to (iv) or the procedure instructed by the instrument manufacturer shall be taken for optimization. The procedures outlined in SAE paper No. 770141 may be optionally used for optimization;
 - (i) The response at a given fuel flow shall be determined from the difference between the span gas response and the zero gas response;
 - (ii) The fuel flow shall be incrementally adjusted above and below the manufacturer's specification. The span and zero response at these fuel flows shall be recorded;
 - (iii) The difference between the span and zero response shall be plotted and the fuel flow adjusted to the rich side of the curve. This is the initial flow rate setting which may need further optimization depending on the results of the hydrocarbon response factors and the oxygen interference check according to points 8.1.10.1.1.(a) and 8.1.10.2.;
 - (iv) If the oxygen interference or the hydrocarbon response factors do not meet the following specifications, the airflow shall be incrementally adjusted above and below the manufacturer's specifications, repeating points 8.1.10.1.1.(a) and 8.1.10.2. for each flow;
- (d) The optimum flow rates and/or pressures for FID fuel and burner air shall be determined, and they shall be sampled and recorded for future reference.

8.1.10.1.4. HC FID CH₄ response factor determination

Since FID analyzers generally have a different response to CH₄ versus C₃H₈, each HC FID analyzer's CH₄ response factor, $RF_{CH_4[THC-FID]}$ shall be determined, after FID optimization. The most recent $RF_{CH_4[THC-FID]}$ measured in accordance with this section shall be used in the calculations for HC determination described in section 2. of Annex VII (mass based approach) or section 3. of Annex VII (molar based approach) to compensate for CH₄ response. $RF_{CH_4[THC-FID]}$ shall be determined as follows:

- (a) A C₃H₈ span gas concentration shall be selected to span the analyzer before emission testing. Only span gases that meet the specifications of point 9.5.1. shall be selected and the C₃H₈ concentration of the gas shall be recorded;
- (b) A CH₄ span gas that meets the specifications of point 9.5.1. shall be selected and the CH₄ concentration of the gas shall be recorded,
- (c) The FID analyzer shall be operated according to the manufacturer's instructions;
- (d) It shall be confirmed that the FID analyzer has been calibrated using C₃H₈. Calibration shall be performed on a carbon number basis of one (C₁);

- (e) The FID shall be zeroed with a zero gas used for emission testing;
- (f) The FID shall be spanned with the selected C₃H₈ span gas;
- (g) The CH₄ span gas selected in accordance with paragraph (b) shall be introduced at the sample port of the FID analyzer;
- (h) The analyzer response shall be stabilized. Stabilization time may include time to purge the analyzer and to account for its response;
- (i) While the analyzer measures the CH₄ concentration, 30 s of sampled data shall be recorded and the arithmetic mean of these values shall be calculated;
- (j) The mean measured concentration shall be divided by the recorded span concentration of the CH₄ calibration gas. The result is the FID analyzer's response factor for CH₄, $RF_{CH_4[THC-FID]}$.

8.1.10.1.5. HC FID methane (CH₄) response verification

If the value of $RF_{CH_4[THC-FID]}$ obtained in accordance with point 8.1.10.1.4. is within $\pm 5,0$ % of its most recent previously determined value, the HC FID passes the methane response verification.

- (a) It shall be first verified that the pressures and / or flow rates of FID fuel, burner air, and sample are each within $\pm 0,5$ % of their most recent previously recorded values, as described in point 8.1.10.1.3.. If these flow rates have to be adjusted, a new $RF_{CH_4[THC-FID]}$ shall be determined as described in point 8.1.10.1.4.. It should be verified that the value of $RF_{CH_4[THC-FID]}$ determined is within the tolerance specified in this point 8.1.10.1.5.;
- (b) If $RF_{CH_4[THC-FID]}$ is not within the tolerance specified in this point 8.1.10.1.5., the FID response shall be re-optimized as described in point 8.1.10.1.3.;
- (c) A new $RF_{CH_4[THC-FID]}$ shall be determined as described in point 8.1.10.1.4.. This new value of $RF_{CH_4[THC-FID]}$ shall be used in the calculations for HC determination, in section 2. of Annex VII (mass based approach) or section 3. of Annex VII (molar based approach).

8.1.10.2. Non-stoichiometric raw exhaust gas FID O₂ interference verification

8.1.10.2.1. Scope and frequency

If FID analyzers are used for raw exhaust gas measurements, the amount of FID O₂ interference shall be verified upon initial installation and after major maintenance.

8.1.10.2.2. Measurement principles

Changes in O₂ concentration in raw exhaust gas can affect FID response by changing FID flame temperature. FID fuel, burner air, and sample flow shall be optimized to meet

this verification. FID performance shall be verified with the compensation algorithms for FID O₂ interference that is active during an emission test.

8.1.10.2.3. System requirements

Any FID analyzer used during testing shall meet the FID O₂ interference verification according to the procedure in this section.

8.1.10.2.4. Procedure

FID O₂ interference shall be determined as follows, noting that one or more gas dividers may be used to create reference gas concentrations that are required to perform this verification:

- (a) Three span reference gases that meet the specifications set out in point 9.5.1. and contain C₃H₈ concentration shall be selected to span the analyzers before emissions testing. CH₄ span reference gases shall be selected for FIDs calibrated on CH₄ with a non-methane cutter. The three balance gas concentrations shall be selected such that the concentrations of O₂ and N₂ represent the minimum and maximum and intermediate O₂ concentrations expected during testing. The requirement for using the average O₂ concentration can be removed if the FID is calibrated with span gas balanced with the average expected oxygen concentration;
- (b) It shall be confirmed that the FID analyzer meets all the specifications of point 8.1.10.1.;
- (c) The FID analyzer shall be started and operated as it would be before an emission test. Regardless of the FID burner's air source during testing, zero air shall be used as the FID burner's air source for this verification;
- (d) The analyzer shall be set at zero;
- (e) The analyzer shall be spanned using a span gas that is used during emissions testing;
- (f) The zero response shall be checked by using the zero gas used during emission testing. It shall be proceeded to the next step if the mean zero response of 30 s of sampled data is within $\pm 0,5$ % of the span reference value used in paragraph (e) of this point, otherwise the procedure shall be restarted at paragraph (d) of this point;
- (g) The analyzer response shall be checked using the span gas that has the minimum concentration of O₂ expected during testing. The mean response of 30 s of stabilized sample data shall be recorded as $x_{O_2\min HC}$;
- (h) The zero response of the FID analyzer shall be checked using the zero gas used during emission testing. The next step shall be performed if the mean zero

response of 30 s of stabilized sample data is within $\pm 0,5$ % of the span reference value used in paragraph (e) of this point, otherwise the procedure shall be restarted at paragraph (d) of this point;

- (i) The analyzer response shall be checked using the span gas that has the average concentration of O_2 expected during testing. The mean response of 30 s of stabilized sample data shall be recorded as $x_{O_2\text{avgHC}}$;
- (j) The zero response of the FID analyzer shall be checked using the zero gas used during emission testing. The next step shall be performed if the mean zero response of 30 s of stabilized sample data is within $\pm 0,5$ % of the span reference value used in paragraph (e) of this point, otherwise the procedure shall be restarted at paragraph (d) of this point;
- (k) The analyzer response shall be checked using the span gas that has the maximum concentration of O_2 expected during testing. The mean response of 30 s of stabilized sample data shall be recorded as $x_{O_2\text{maxHC}}$;
- (l) The zero response of the FID analyzer shall be checked using the zero gas used during emission testing. The next step shall be performed if the mean zero response of 30 s of stabilized sample data is within $\pm 0,5$ % of the span reference value used in paragraph (e) of this point, otherwise the procedure shall be restarted at paragraph (d) of this point;
- (m) The % difference between $x_{O_2\text{maxHC}}$ and its reference gas concentration shall be calculated. The percent difference between $x_{O_2\text{avgHC}}$ and its reference gas concentration shall be calculated. The % difference between $x_{O_2\text{minHC}}$ and its reference gas concentration shall be calculated. The maximum % difference of the three shall be determined. This is the O_2 interference;
- (n) If the O_2 interference is within ± 3 %, the FID passes the O_2 interference verification; otherwise one or more of the following need to be performed to address the deficiency:
 - (i) The verification shall be repeated to determine if a mistake was made during the procedure;
 - (ii) The zero and span gases for emission testing shall be selected that contain higher or lower O_2 concentrations and the verification shall be repeated;
 - (iii) The FID burner air, fuel, and sample flow rates shall be adjusted. Note that if these flow rates are adjusted on a THC FID to meet the O_2 interference verification, the RF_{CH_4} shall be reset for the next RF_{CH_4} verification. The O_2 interference verification shall be repeated after adjustment and RF_{CH_4} shall be determined;
 - (iv) The FID shall be repaired or replaced and the O_2 interference verification shall be repeated.

8.1.10.3. Non-methane cutter penetration fractions (Reserved)

8.1.11. NO_x measurements

8.1.11.1. CLD CO₂ and H₂O quench verification

8.1.11.1.1. Scope and frequency

If a CLD analyzer is used to measure NO_x, the amount of H₂O and CO₂ quench shall be verified after installing the CLD analyzer and after major maintenance.

8.1.11.1.2. Measurement principles

H₂O and CO₂ can negatively interfere with a CLD's NO_x response by collisional quenching, which inhibits the chemiluminescent reaction that a CLD utilizes to detect NO_x. This procedure and the calculations in point 8.1.11.2.3. determine quench and scale the quench results to the maximum mole fraction of H₂O and the maximum CO₂ concentration expected during emission testing. If the CLD analyzer uses quench compensation algorithms that utilize H₂O and/or CO₂ measurement instruments, quench shall be evaluated with these instruments active and with the compensation algorithms applied.

8.1.11.1.3. System requirements

For dilute measurement a CLD analyzer shall not exceed a combined H₂O and CO₂ quench of ± 2 %. For raw measurement a CLD analyzer shall not exceed a combined H₂O and CO₂ quench of $\pm 2,5$ %. Combined quench is the sum of the CO₂ quench determined as described in point 8.1.11.1.4. and the H₂O quench as determined in point 8.1.11.1.5. If these requirements are not met, corrective action shall be taken by repairing or replacing the analyzer. Before running emission tests, it shall be verified that the corrective action have successfully restored the analyzer to proper functioning.

8.1.11.1.4. CO₂ quench verification procedure

The following method or the method prescribed by the instrument manufacturer may be used to determine CO₂ quench by using a gas divider that blends binary span gases with zero gas as the diluent and meets the specifications in point 9.4.5.6., or good engineering judgment shall be used to develop a different protocol:

- (a) PTFE or stainless steel tubing shall be used to make necessary connections;
- (b) The gas divider shall be configured such that nearly equal amounts of the span and diluent gases are blended with each other;
- (c) If the CLD analyzer has an operating mode in which it detects NO-only, as opposed to total NO_x, the CLD analyzer shall be operated in the NO-only operating mode;

- (d) A CO₂ span gas that meets the specifications of point 9.5.1. and a concentration that is approximately twice the maximum CO₂ concentration expected during emission testing shall be used;
- (e) An NO span gas that meets the specifications of point 9.5.1. and a concentration that is approximately twice the maximum NO concentration expected during emission testing shall be used. Higher concentration may be used according to the instrument manufacturer's recommendation and good engineering judgement in order to obtain accurate verification, if the expected NO concentration is lower than the minimum range for the verification specified by the instrument manufacturer;
- (f) The CLD analyzer shall be zeroed and spanned. The CLD analyzer shall be spanned with the NO span gas from paragraph (e) of this point through the gas divider. The NO span gas shall be connected to the span port of the gas divider; a zero gas shall be connected to the diluent port of the gas divider; the same nominal blend ratio shall be used as selected in paragraph (b) of this point; and the gas divider's output concentration of NO shall be used to span the CLD analyzer. Gas property corrections shall be applied as necessary to ensure accurate gas division;
- (g) The CO₂ span gas shall be connected to the span port of the gas divider;
- (h) The NO span gas shall be connected to the diluents port of the gas divider;
- (i) While flowing NO and CO₂ through the gas divider, the output of the gas divider shall be stabilized. The CO₂ concentration from the gas divider output shall be determined, applying gas property correction as necessary to ensure accurate gas division. This concentration, $x_{\text{CO}_2\text{act}}$, shall be recorded and it shall be used in the quench verification calculations in point 8.1.11.2.3.. As an alternative to using a gas divider, another simple gas blending device may be used. In this case an analyzer shall be used to determine CO₂ concentration. If a NDIR is used together with a simple gas blending device, it shall meet the requirements of this section and it shall be spanned with the CO₂ span gas from paragraph (d) of this point. The linearity of the NDIR analyzer has to be checked before over the whole range up to twice of the expected maximum CO₂ concentration expected during testing;
- (j) The NO concentration shall be measured downstream of the gas divider with the CLD analyzer. Time shall be allowed for the analyzer response to stabilize. Stabilization time may include time to purge the transfer line and to account for analyzer response. While the analyzer measures the sample's concentration, the analyzer's output shall be recorded for 30 seconds. The arithmetic mean concentration shall be calculated from these data, x_{NOmeas} . x_{NOmeas} shall be recorded and it shall be used in the quench verification calculations in point 8.1.11.2.3.;

- (k) The actual NO concentration shall be calculated at the gas divider's outlet, x_{NOact} , based on the span gas concentrations and x_{CO2act} by means of equation (6-24). The calculated value shall be used in the quench verification calculations by means of equation (6-23);
- (l) The values recorded according to this points 8.1.11.1.4. and 8.1.11.1.5. shall be used to calculate quench as described in point 8.1.11.2.3..

8.1.11.1.5. H₂O quench verification procedure

The following method or the method prescribed by the instrument manufacturer may be used to determine H₂O quench, or good engineering judgment shall be used to develop a different protocol:

- (a) PTFE or stainless steel tubing shall be used to make necessary connections;
- (b) If the CLD analyzer has an operating mode in which it detects NO-only, as opposed to total NO_x, the CLD analyzer shall be operated in the NO-only operating mode;
- (c) A NO span gas shall be used that meets the specifications of point 9.5.1. and a concentration that is near the maximum concentration expected during emission testing. Higher concentration may be used according to the instrument manufacturer's recommendation and good engineering judgement in order to obtain accurate verification, if the expected NO concentration is lower than the minimum range for the verification specified by the instrument manufacturer;
- (d) The CLD analyzer shall be zeroed and spanned. The CLD analyzer shall be spanned with the NO span gas from paragraph (c) of this point, the span gas concentration shall be recorded as x_{NOdry} , and it shall be used in the quench verification calculations in point 8.1.11.2.3.;
- (e) The NO span gas shall be humidified by bubbling it through distilled water in a sealed vessel. If the humidified NO span gas sample does not pass through a sample dryer for this verification test, the vessel temperature shall be controlled to generate an H₂O level approximately equal to the maximum mole fraction of H₂O expected during emission testing. If the humidified NO span gas sample does not pass through a sample dryer, the quench verification calculations in point 8.1.11.2.3. scale the measured H₂O quench to the highest mole fraction of H₂O expected during emission testing. If the humidified NO span gas sample passes through a dryer for this verification test, the vessel temperature shall be controlled to generate an H₂O level at least as high as the level required in point 9.3.2.3.1. For this case, the quench verification calculations set out in point 8.1.11.2.3. do not scale the measured H₂O quench;
- (f) The humidified NO test gas shall be introduced into the sample system. It may be introduced upstream or downstream of a sample dryer that is used during emission testing. Depending on the point of introduction, the respective calculation method

of paragraph (e) of this point shall be selected. Note that the sample dryer shall meet the sample dryer verification check in point 8.1.8.5.8.;

- (g) The mole fraction of H₂O in the humidified NO span gas shall be measured. In case a sample dryer is used, the mole fraction of H₂O in the humidified NO span gas shall be measured downstream of the sample dryer, $x_{\text{H}_2\text{O}_{\text{meas}}}$. It is recommended to measure $x_{\text{H}_2\text{O}_{\text{meas}}}$ as close as possible to the CLD analyzer inlet. $x_{\text{H}_2\text{O}_{\text{meas}}}$ may be calculated from measurements of dew point, T_{dew} , and absolute pressure, p_{total} ;
- (h) Good engineering judgment shall be used to prevent condensation in the transfer lines, fittings, or valves from the point where $x_{\text{H}_2\text{O}_{\text{meas}}}$ is measured to the analyzer. It is recommended that the system is designed so the wall temperatures in the transfer lines, fittings, and valves from the point where $x_{\text{H}_2\text{O}_{\text{meas}}}$ is measured to the analyzer are at least 5 K above the local sample gas dew point;
- (i) The humidified NO span gas concentration shall be measured with the CLD analyzer. Time shall be allowed for the analyzer response to stabilize. Stabilization time may include time to purge the transfer line and to account for analyzer response. While the analyzer measures the sample's concentration, the analyzer's output shall be recorded for 30 seconds. The arithmetic mean shall be calculated of these data, $x_{\text{NO}_{\text{wet}}}$. $x_{\text{NO}_{\text{wet}}}$ shall be recorded and used in the quench verification calculations in point 8.1.11.2.3..

8.1.11.2. CLD quench verification calculations

CLD quench-check calculations shall be performed as described in this point.

8.1.11.2.1. Amount of water expected during testing

The maximum expected mole fraction of water during emission testing, $x_{\text{H}_2\text{O}_{\text{exp}}}$ shall be estimated. This estimate shall be made where the humidified NO span gas was introduced in point 8.1.11.1.5.(f). When estimating the maximum expected mole fraction of water, the maximum expected water content in combustion air, fuel combustion products, and dilution air (if applicable) shall be considered. If the humidified NO span gas is introduced into the sample system upstream of a sample dryer during the verification test, it is not needed to estimate the maximum expected mole fraction of water and $x_{\text{H}_2\text{O}_{\text{exp}}}$ shall be set equal to $x_{\text{H}_2\text{O}_{\text{meas}}}$.

8.1.11.2.2. Amount of CO₂ expected during testing

The maximum expected CO₂ concentration during emission testing, $x_{\text{CO}_2_{\text{exp}}}$ shall be estimated. This estimate shall be made at the sample system location where the blended NO and CO₂ span gases are introduced according to point 8.1.11.1.4.(j). When estimating the maximum expected CO₂ concentration, the maximum expected CO₂ content in fuel combustion products and dilution air shall be considered.

8.1.11.2.3. Combined H₂O and CO₂ quench calculations

Combined H₂O and CO₂ quench shall be calculated by means of equation (6-23):

$$quench = \left[\left(\frac{x_{NOwet}}{1 - x_{H_2Omeas}} - 1 \right) \cdot \frac{x_{H_2Oexp}}{x_{H_2Omeas}} + \left(\frac{x_{NOmeas}}{x_{NOact}} - 1 \right) \cdot \frac{x_{CO_2exp}}{x_{CO_2act}} \right] \cdot 100\% \quad (6-23)$$

Where:

quench = amount of CLD quench

x_{NOdry} is the measured concentration of NO upstream of a bubbler, in accordance with point 8.1.11.1.5.(d)

x_{NOwet} is the measured concentration of NO downstream of a bubbler, in accordance with point 8.1.11.1.5.(i)

x_{H_2Oexp} is the maximum expected mole fraction of water during emission testing in accordance with point 8.1.11.2.1.

x_{H_2Omeas} is the measured mole fraction of water during the quench verification in accordance with point 8.1.11.1.5.(g)

x_{NOmeas} is the measured concentration of NO when NO span gas is blended with CO₂ span gas, in accordance with point 8.1.11.1.4.(j)

x_{NOact} is the actual concentration of NO when NO span gas is blended with CO₂ span gas, in accordance with point 8.1.11.1.4.(k) and calculated by means of equation (6-24)

x_{CO_2exp} is the maximum expected concentration of CO₂ during emission testing, in accordance with point 8.1.11.2.2.

x_{CO_2act} is the actual concentration of CO₂ when NO span gas is blended with CO₂ span gas, in accordance with point 8.1.11.1.4.(i)

$$x_{NOact} = \left(1 - \frac{x_{CO_2act}}{x_{CO_2span}} \right) \cdot x_{NOspan} \quad (6-24)$$

Where:

x_{NOspan}	is the the NO span gas concentration input to the gas divider, in accordance with point 8.1.11.1.4.(e)
x_{CO2span}	is the the CO ₂ span gas concentration input to the gas divider, in accordance with point 8.1.11.1.4.(d)

8.1.11.3. NDUV analyzer HC and H₂O interference verification

8.1.11.3.1. Scope and frequency

If NO_x is measured using an NDUV analyzer, the amount of H₂O and hydrocarbon interference shall be verified after initial analyzer installation and after major maintenance.

8.1.11.3.2. Measurement principles

Hydrocarbons and H₂O can positively interfere with a NDUV analyzer by causing a response similar to NO_x. If the NDUV analyzer uses compensation algorithms that utilize measurements of other gases to meet this interference verification, simultaneously such measurements shall be conducted to test the algorithms during the analyzer interference verification.

8.1.11.3.3. System requirements

A NO_x NDUV analyzer shall have combined H₂O and HC interference within ±2 % of the mean concentration of NO_x.

8.1.11.3.4. Procedure

The interference verification shall be performed as follows:

- The NO_x NDUV analyzer shall be started, operated, zeroed, and spanned according to the instrument manufacturer's instructions;
- It is recommended to extract engine exhaust gas to perform this verification. A CLD shall be used that meets the specifications of point 9.4. to quantify NO_x in the exhaust gas. The CLD response shall be used as the reference value. Also HC shall be measured in the exhaust gas with a FID analyzer that meets the specifications of point 9.4.. The FID response shall be used as the reference hydrocarbon value;
- Upstream of any sample dryer, if one is used during testing, the engine exhaust gas shall be introduced into the NDUV analyzer;
- Time shall be allowed for the analyzer response to stabilize. Stabilization time may include time to purge the transfer line and to account for analyzer response;
- While all analyzers measure the sample's concentration, 30 s of sampled data shall be recorded, and the arithmetic means for the three analyzers calculated;

- (f) The CLD mean shall be subtracted from the NDUV mean;
- (g) This difference shall be multiplied by the ratio of the expected mean HC concentration to the HC concentration measured during the verification. The analyzer meets the interference verification of this point if this result is within ± 2 % of the NO_x concentration expected at the standard, as set out in equation (6-25):

$$\left| \bar{x}_{\text{NO}_x, \text{CLD}, \text{meas}} - \bar{x}_{\text{NO}_x, \text{NDUV}, \text{meas}} \right| \cdot \left(\frac{\bar{x}_{\text{HC}, \text{exp}}}{\bar{x}_{\text{HC}, \text{meas}}} \right) \leq 2\% \cdot (\bar{x}_{\text{NO}_x, \text{exp}}) \quad (6-25)$$

Where:

- $\bar{x}_{\text{NO}_x, \text{CLD}, \text{meas}}$ is the the mean concentration of NO_x measured by CLD [$\mu\text{mol/mol}$] or [ppm]
- $\bar{x}_{\text{NO}_x, \text{NDUV}, \text{meas}}$ is the mean concentration of NO_x measured by NDUV [$\mu\text{mol/mol}$] or [ppm]
- $\bar{x}_{\text{HC}, \text{meas}}$ is the mean concentration of HC measured [$\mu\text{mol/mol}$] or [ppm]
- $\bar{x}_{\text{HC}, \text{exp}}$ is the mean concentration of HC expected at the standard [$\mu\text{mol/mol}$] or [ppm]
- $\bar{x}_{\text{NO}_x, \text{exp}}$ is the mean concentration of NO_x expected at the standard [$\mu\text{mol/mol}$] or [ppm]

8.1.11.4 Sample dryer NO_2 penetration

8.1.11.4.1. Scope and frequency

If a sample dryer is used to dry a sample upstream of a NO_x measurement instrument, but no NO_2 -to-NO converter is used upstream of the sample dryer, this verification shall be performed for sample dryer NO_2 penetration. This verification shall be performed after initial installation and after major maintenance.

8.1.11.4.2. Measurement principles

A sample dryer removes water, which can otherwise interfere with a NO_x measurement. However, liquid water remaining in an improperly designed cooling bath can remove NO_2 from the sample. If a sample dryer is used without an NO_2 -to-NO converter upstream, it could therefore remove NO_2 from the sample prior NO_x measurement.

8.1.11.4.3. System requirements

The sample dryer shall allow for measuring at least 95 % of the total NO_2 at the maximum expected concentration of NO_2 .

8.1.11.4.4. Procedure

The following procedure shall be used to verify sample dryer performance:

- (a) Instrument setup. The analyzer and sample dryer manufacturers' start-up and operating instructions shall be followed. The analyzer and sample dryer shall be adjusted as needed to optimize performance;
- (b) Equipment setup and data collection.
 - (i) The total NO_x gas analyzer(s) shall be zeroed and spanned as it would be before emission testing;
 - (ii) NO₂ calibration gas (balance gas of dry air) that has an NO₂ concentration that is near the maximum expected during testing shall be selected. Higher concentration may be used in accordance with the instrument manufacturer's recommendation and good engineering judgement in order to obtain accurate verification, if the expected NO₂ concentration is lower than the minimum range for the verification specified by the instrument manufacturer;
 - (iii) This calibration gas shall be overflowed at the gas sampling system's probe or overflow fitting. Time shall be allowed for stabilization of the total NO_x response, accounting only for transport delays and instrument response;
 - (iv) The mean of 30 s of recorded total NO_x data shall be calculated and this value recorded as $x_{\text{NO}_x\text{ref}}$;
 - (v) The flowing the NO₂ calibration gas shall be stopped;
 - (vi) Next the sampling system shall be saturated by overflowing a dew point generator's output, set at a dew point of 323 K (50 °C), to the gas sampling system's probe or overflow fitting. The dew point generator's output shall be sampled through the sampling system and sample dryer for at least 10 minutes until the sample dryer is expected to be removing a constant rate of water;
 - (vii) It shall be immediately switched back to overflowing the NO₂ calibration gas used to establish $x_{\text{NO}_x\text{ref}}$. It shall be allowed for stabilization of the total NO_x response, accounting only for transport delays and instrument response. The mean of 30 s of recorded total NO_x data shall be calculated and this value recorded as $x_{\text{NO}_x\text{meas}}$;
 - (viii) $x_{\text{NO}_x\text{meas}}$ shall be corrected to $x_{\text{NO}_x\text{dry}}$ based upon the residual water vapour that passed through the sample dryer at the sample dryer's outlet temperature and pressure;

- (c) Performance evaluation. If $x_{\text{NO}_x\text{dry}}$ is less than 95 % of $x_{\text{NO}_x\text{ref}}$, the sample dryer shall be repaired or replaced.

8.1.11.5. NO₂-to-NO converter conversion verification

8.1.11.5.1. Scope and frequency

If an analyzer is used that measures only NO to determine NO_x, an NO₂-to-NO converter shall be used upstream of the analyzer. This verification shall be performed after installing the converter, after major maintenance and within 35 days before an emission test. This verification shall be repeated at this frequency to verify that the catalytic activity of the NO₂-to-NO converter has not deteriorated.

8.1.11.5.2. Measurement principles

An NO₂-to-NO converter allows an analyzer that measures only NO to determine total NO_x by converting the NO₂ in exhaust gas to NO.

8.1.11.5.3. System requirements

An NO₂-to-NO converter shall allow for measuring at least 95 % of the total NO₂ at the maximum expected concentration of NO₂.

8.1.11.5.4 Procedure

The following procedure shall be used to verify the performance of a NO₂-to-NO converter:

- (a) For the instrument setup the analyzer and NO₂-to-NO converter manufacturers' start-up and operating instructions shall be followed. The analyzer and converter shall be adjusted as needed to optimize performance;
- (b) An ozonator's inlet shall be connected to a zero-air or oxygen source and its outlet shall be connected to one port of a 3-way tee fitting. An NO span gas shall be connected to another port and the NO₂-to-NO converter inlet shall be connected to the last port;
- (c) The following steps shall be taken when performing this check:
 - (i) The ozonator air shall be set off and the ozonator power shall be turned off and the NO₂-to-NO converter shall be set to the bypass mode (i.e., NO mode). Stabilization shall be allowed for, accounting only for transport delays and instrument response;
 - (ii) The NO and zero-gas flows shall be adjusted so the NO concentration at the analyzer is near the peak total NO_x concentration expected during testing. The NO₂ content of the gas mixture shall be less than 5 % of the NO concentration. The concentration of NO shall be recorded by calculating the

mean of 30 s of sampled data from the analyzer and this value shall be recorded as x_{NOref} . Higher concentration may be used according to the instrument manufacturer's recommendation and good engineering judgement in order to obtain accurate verification, if the expected NO concentration is lower than the minimum range for the verification specified by the instrument manufacturer;

- (iii) The ozonator O₂ supply shall be turned on and the O₂ flow rate adjusted so that the NO indicated by the analyzer is about 10 percent less than x_{NOref} . The concentration of NO shall be recorded by calculating the mean of 30 s of sampled data from the analyzer and this value recorded as $x_{\text{NO+O2mix}}$;
 - (iv) The ozonator shall be switched on and the ozone generation rate adjusted so that the NO measured by the analyzer is approximately 20 percent of x_{NOref} , while maintaining at least 10 % unreacted NO. The concentration of NO shall be recorded by calculating the mean of 30 s of sampled data from the analyzer and this value shall be recorded as x_{NOmeas} ;
 - (v) The NO_x analyzer shall be switched to NO_x mode and total NO_x measured. The concentration of NO_x shall be recorded by calculating the mean of 30 s of sampled data from the analyzer and this value shall be recorded as x_{NOxmeas} ;
 - (vi) The ozonator shall be switched off but gas flow through the system shall be maintained. The NO_x analyzer will indicate the NO_x in the NO + O₂ mixture. The concentration of NO_x shall be recorded by calculating the mean of 30 s of sampled data from the analyzer and this value shall be recorded as $x_{\text{NOx+O2mix}}$;
 - (vii) O₂ supply shall be turned off. The NO_x analyzer will indicate the NO_x in the original NO-in-N₂ mixture. The concentration of NO_x shall be recorded by calculating the mean of 30 s of sampled data from the analyzer and this value shall be recorded as x_{NOxref} . This value shall be no more than 5 % above the x_{NOref} value;
- (d) Performance evaluation. The efficiency of the NO_x converter shall be calculated by substituting the concentrations obtained into equation (6-26):

$$\text{Efficiency}[\%] = \left(1 + \frac{x_{\text{NOxmeas}} - x_{\text{NOx+O2mix}}}{x_{\text{NO+O2mix}} - x_{\text{NOmeas}}} \right) \times 100 \quad (6-26)$$

- (e) If the result is less than 95 %, the NO₂-to-NO converter shall be repaired or replaced.

8.1.12. PM measurements

8.1.12.1. PM balance verifications and weighing process verification

8.1.12.1.1. Scope and frequency

This section describes three verifications.

- (a) Independent verification of PM balance performance within 370 days prior to weighing any filter;
- (b) Zero and span of the balance within 12 h prior to weighing any filter;
- (c) Verification that the mass determination of reference filters before and after a filter weighing session be less than a specified tolerance.

8.1.12.1.2. Independent verification

The balance manufacturer (or a representative approved by the balance manufacturer) shall verify the balance performance within 370 days of testing in accordance with internal audit procedures.

8.1.12.1.3. Zeroing and spanning

Balance performance shall be verified by zeroing and spanning it with at least one calibration weight, and any weights that are used shall meet the specifications in point 9.5.2. to perform this verification. A manual or automated procedure shall be used:

- (a) A manual procedure requires that the balance shall be used in which the balance shall be zeroed and spanned with at least one calibration weight. If normally mean values are obtained by repeating the weighing process to improve the accuracy and precision of PM measurements, the same process shall be used to verify balance performance;
- (b) An automated procedure is carried out with internal calibration weights that are used automatically to verify balance performance. These internal calibration weights shall meet the specifications in point 9.5.2. to perform this verification.

8.1.12.1.4. Reference sample weighing

All mass readings during a weighing session shall be verified by weighing reference PM sample media (e.g. filters) before and after a weighing session. A weighing session may be as short as desired, but no longer than 80 hours, and may include both pre- and post-test mass readings. Successive mass determinations of each reference PM sample media shall return the same value within $\pm 10 \mu\text{g}$ or $\pm 10 \%$ of the expected total PM mass, whichever is higher. Should successive PM sample filter weighing events fail this criterion, all

individual test filter mass readings mass readings occurring between the successive reference filter mass determinations shall be invalidated. These filters may be re-weighed in another weighing session. Should a post-test filter be invalidated then the test interval is void. This verification shall be performed as follows:

- (d) At least two samples of unused PM sample media shall be kept in the PM-stabilization environment. These shall be used as references. Unused filters of the same material and size shall be selected for use as references;
- (e) References shall be stabilized in the PM stabilization environment. References shall be considered stabilized if they have been in the PM-stabilization environment for a minimum of 30 min, and the PM-stabilization environment has been within the specifications of point 9.3.4.4. for at least the preceding 60 min;
- (f) The balance shall be exercised several times with a reference sample without recording the values;
- (g) The balance shall be zeroed and spanned. A test mass shall be placed on the balance (e.g. calibration weight) and then removed ensuring that the balance returns to an acceptable zero reading within the normal stabilization time;
- (h) Each of the reference media (e.g. filters) shall be weighed and their masses recorded. If normally mean values are obtained by repeating the weighing process to improve the accuracy and precision of reference media (e.g. filters) masses, the same process shall be used to measure mean values of sample media (e.g. filters) masses;
- (i) The balance environment dew point, ambient temperature, and atmospheric pressure shall be recorded;
- (j) The recorded ambient conditions shall be used to correct results for buoyancy as described in point 8.1.13.2.. The buoyancy-corrected mass of each of the references shall be recorded;
- (k) Each of the reference media's (e.g. filter's) buoyancy-corrected reference mass shall be subtracted from its previously measured and recorded buoyancy-corrected mass;
- (l) If any of the reference filters' observed mass changes by more than that allowed under this section, all PM mass determinations made since the last successful reference media (e.g. filter) mass validation shall be invalidated. Reference PM filters may be discarded if only one of the filters mass has changed by more than the allowable amount and a special cause for that filter's mass change can be positively identified which would not have affected other in-process filters. Thus the validation can be considered a success. In this case, the contaminated reference media shall not be included when determining compliance with

paragraph (j) of this point, but the affected reference filter shall be discarded and replaced;

- (m) If any of the reference masses change by more than that allowed under this point 8.1.13.1.4., all PM results that were determined between the two times that the reference masses were determined shall be invalidated. If reference PM sample media is discarded in accordance with paragraph (i) of this point, at least one reference mass difference that meets the criteria set out in point 8.1.13.1.4. shall be available. Otherwise, all PM results that were determined between the two times that the reference media (e.g. filters) masses were determined shall be invalidated.

8.1.12.2. PM sample filter buoyancy correction

8.1.12.2.1. General

PM sample filter shall be corrected for their buoyancy in air. The buoyancy correction depends on the sample media density, the density of air, and the density of the calibration weight used to calibrate the balance. The buoyancy correction does not account for the buoyancy of the PM itself, because the mass of PM typically accounts for only (0,01 to 0,10) % of the total weight. A correction to this small fraction of mass would be at the most 0,010 %. The buoyancy-corrected values are the tare masses of the PM samples. These buoyancy-corrected values of the pre-test filter weighing are subsequently subtracted from the buoyancy-corrected values of the post-test weighing of the corresponding filter to determine the mass of PM emitted during the test.

8.1.12.2.2. PM sample filter density

Different PM sample filter have different densities. The known density of the sample media shall be used, or one of the densities for some common sampling media shall be used, as follows:

- (a) For PTFE-coated borosilicate glass, a sample media density of 2300 kg/m^3 shall be used;
- (b) For PTFE membrane (film) media with an integral support ring of polymethylpentene that accounts for 95 % of the media mass, a sample media density of 920 kg/m^3 shall be used;
- (c) For PTFE membrane (film) media with an integral support ring of PTFE, a sample media density of 2144 kg/m^3 shall be used.

8.1.12.2.3. Air density

Because a PM balance environment shall be tightly controlled to an ambient temperature of $295 \pm 1 \text{ K}$ ($22 \pm 1^\circ\text{C}$) and a dew point of $282,5 \pm 1 \text{ K}$ ($9,5 \pm 1^\circ\text{C}$),

air density is primarily function of atmospheric pressure. Therefore a buoyancy correction is specified that is only a function of atmospheric pressure.

8.1.12.2.4. Calibration weight density

The stated density of the material of the metal calibration weight shall be used.

8.1.12.2.5. Correction calculation

The PM sample filter shall be corrected for buoyancy by means of equation (6-27):

$$m_{\text{cor}} = m_{\text{uncor}} \cdot \left(\frac{1 - \frac{\rho_{\text{air}}}{\rho_{\text{weight}}}}{1 - \frac{\rho_{\text{air}}}{\rho_{\text{media}}}} \right) \quad (6-27)$$

Where:

- m_{cor} is the PM sample filter mass corrected for buoyancy
- m_{uncor} is the PM sample filter mass uncorrected for buoyancy
- ρ_{air} is the density of air in balance environment
- ρ_{weight} is the density of calibration weight used to span balance
- ρ_{media} is the density of PM sample filter

with

$$\rho_{\text{air}} = \frac{p_{\text{abs}} \cdot M_{\text{mix}}}{R \cdot T_{\text{amb}}} \quad (6-28)$$

Where:

- p_{abs} is the absolute pressure in balance environment
- M_{mix} is the molar mass of air in balance environment
- R is the molar gas constant.
- T_{amb} is the absolute ambient temperature of balance environment

8.2. Instrument validation for test

8.2.1. Validation of proportional flow control for batch sampling and minimum dilution ratio for PM batch sampling

8.2.1.1. Proportionality criteria for CVS

8.2.1.1.1. Proportional flows

For any pair of flow meters, the recorded sample and total flow rates or their 1 Hz means shall be used with the statistical calculations in Appendix 3 of Annex VII. The standard error of the estimate, *SEE*, of the sample flow rate versus the total flow rate shall be determined. For each test interval, it shall be demonstrated that *SEE* was less than or equal to 3,5 % of the mean sample flow rate.

8.2.1.1.2. Constant flows

For any pair of flow meters, the recorded sample and total flow rates or their 1 Hz means shall be used to demonstrate that each flow rate was constant within $\pm 2,5$ % of its respective mean or target flow rate. The following options may be used instead of recording the respective flow rate of each type of meter:

- (a) Critical-flow venturi option. For critical-flow venturis, the recorded venturi-inlet conditions or their 1 Hz means shall be used. It shall be demonstrated that the flow density at the venturi inlet was constant within $\pm 2,5$ % of the mean or target density over each test interval. For a CVS critical-flow venturi, this may be demonstrated by showing that the absolute temperature at the venturi inlet was constant within ± 4 % of the mean or target absolute temperature over each test interval;
- (b) Positive-displacement pump option. The recorded pump-inlet conditions or their 1 Hz means shall be used. It shall be demonstrated that the flow density at the pump inlet was constant within $\pm 2,5$ % of the mean or target density over each test interval. For a CVS pump, this may be demonstrated by showing that the absolute temperature at the pump inlet was constant within ± 2 % of the mean or target absolute temperature over each test interval.

8.2.1.1.3. Demonstration of proportional sampling

For any proportional batch sample such as a bag or PM filter, it shall be demonstrated that proportional sampling was maintained using one of the following, noting that up to 5 % of the total number of data points may be omitted as outliers.

Using good engineering judgment, it shall be demonstrated with an engineering analysis that the proportional-flow control system inherently ensures proportional sampling under all circumstances expected during testing. For example, CFVs may be used for both sample flow and total flow if it is demonstrated that they always have the same inlet pressures and temperatures and that they always operate under critical-flow conditions.

Measured or calculated flows and/or tracer gas concentrations (e.g. CO₂) shall be used to determine the minimum dilution ratio for PM batch sampling over the test interval.

8.2.1.2. Partial flow dilution system validation

For the control of a partial flow dilution system to extract a proportional raw exhaust gas sample, a fast system response is required; this is identified by the promptness of the partial flow dilution system. The transformation time for the system shall be determined in accordance with the procedure set out in point 8.1.8.6.3.2.. The actual control of the partial flow dilution system shall be based on the current measured conditions. If the combined transformation time of the exhaust gas flow measurement and the partial flow system is $\leq 0,3$ s, online control shall be used. If the transformation time exceeds 0,3 s, look-ahead control based on a pre-recorded test run shall be used. In this case, the combined rise time shall be ≤ 1 s and the combined delay time ≤ 10 s. The total system response shall be designed as to ensure a representative sample of the particulates, $q_{mp,i}$ (sample flow of exhaust gas into partial flow dilution system), proportional to the exhaust gas mass flow. To determine the proportionality, a regression analysis of $q_{mp,i}$ versus $q_{mew,i}$ (exhaust gas mass flow rate on wet basis) shall be conducted on a minimum 5 Hz data acquisition rate, and the following criteria shall be met:

- (a) The correlation coefficient r^2 of the linear regression between $q_{mp,i}$ and $q_{mew,i}$ shall not be less than 0,95;
- (b) The standard error of estimate of $q_{mp,i}$ on $q_{mew,i}$ shall not exceed 5 % of q_{mp} maximum;
- (c) q_{mp} intercept of the regression line shall not exceed ± 2 % of q_{mp} maximum.

Look-ahead control is required if the combined transformation times of the particulate system, $t_{50,P}$ and of the exhaust gas mass flow signal, $t_{50,F}$ are $> 0,3$ s. In this case, a pre-test shall be run and the exhaust gas mass flow signal of the pre-test be used for controlling the sample flow into the particulate system. A correct control of the partial dilution system is obtained, if the time trace of $q_{mew,pre}$ of the pre-test, which controls q_{mp} , is shifted by a "look-ahead" time of $t_{50,P} + t_{50,F}$.

For establishing the correlation between $q_{mp,i}$ and $q_{mew,i}$ the data taken during the actual test shall be used, with $q_{mew,i}$ time aligned by $t_{50,F}$ relative to $q_{mp,i}$ (no contribution from $t_{50,P}$ to the time alignment). The time shift between q_{mew} and q_{mp} is the difference between their transformation times that were determined in point 8.1.8.6.3.2..

8.2.2. Gas analyzer range validation, drift validation and drift correction

8.2.2.1. Range validation

If an analyzer operated above 100 % of its range at any time during the test, the following steps shall be performed:

8.2.2.1.1. Batch sampling

For batch sampling, the sample shall be re-analyzed using the lowest analyzer range that results in a maximum instrument response below 100 %. The result shall be reported from the lowest range from which the analyzer operates below 100 % of its range for the entire test.

8.2.2.1.2. Continuous sampling

For continuous sampling, the entire test shall be repeated using the next higher analyzer range. If the analyzer again operates above 100 % of its range, the test shall be repeated using the next higher range. The test shall be continued to be repeated until the analyzer always operates at less than 100 % of its range for the entire test.

8.2.2.2. Drift validation and drift correction

If the drift is within ± 1 %, the data can be either accepted without any correction or accepted after correction. If the drift is greater than ± 1 %, two sets of brake specific emission results shall be calculated for each pollutant with a brake-specific limit value and for CO₂, or the test shall be voided. One set shall be calculated using data before drift correction and another set of data calculated after correcting all the data for drift in accordance with point 2.6. of Annex VII and Appendix 1 of Annex VII. The comparison shall be made as a percentage of the uncorrected results. The difference between the uncorrected and the corrected brake-specific emission values shall be within ± 4 % of either the uncorrected brake-specific emission values or the emission limit value, whichever is greater. If not, the entire test is void.

8.2.3. PM sampling media (e.g. filters) preconditioning and tare weighing

Before an emission test, the following steps shall be taken to prepare PM sample filter media and equipment for PM measurements:

8.2.3.1. Periodic verifications

It shall be made sure that the balance and PM-stabilization environments meet the periodic verifications in point 8.1.12.. The reference filter shall be weighed just before weighing test filters to establish an appropriate reference point (see section details of the procedure in point 8.1.12.1.). The verification of the stability of the reference filters shall occur after the post-test stabilisation period, immediately before the post-test weighing.

8.2.3.2. Visual Inspection

The unused sample filter media shall be visually inspected for defects, defective filters shall be discarded.

8.2.3.3. Grounding

Electrically grounded tweezers or a grounding strap shall be used to handle PM filters as described in point 9.3.4..

8.2.3.4. Unused sample media

Unused sample media shall be placed in one or more containers that are open to the PM-stabilization environment. If filters are used, they may be placed in the bottom half of a filter cassette.

8.2.3.5. Stabilization

Sample media shall be stabilized in the PM-stabilization environment. An unused sample medium can be considered stabilized as long as it has been in the PM-stabilization environment for a minimum of 30 min, during which the PM-stabilization environment has been within the specifications of point 9.3.4.. However, if a mass of 400 µg or more is expected, then the sample media shall be stabilised for at least 60 min.

8.2.3.6. Weighing

The sample media shall be weighed automatically or manually, as follows:

- (a) For automatic weighing, the automation system manufacturer's instructions shall be followed to prepare samples for weighing; this may include placing the samples in a special container;
- (b) For manual weighing, good engineering judgment shall be used;
- (c) Optionally, substitution weighing is permitted (see point 8.2.3.10.);
- (d) Once a filter is weighed it shall be returned to the Petri dish and covered.

8.2.3.7. Buoyancy correction

The measured weight shall be corrected for buoyancy as described in point 8.1.13.2..

8.2.3.8. Repetition

The filter mass measurements may be repeated to determine the average mass of the filter using good engineering judgement and to exclude outliers from the calculation of the average.

8.2.3.9. Tare-weighing

Unused filters that have been tare-weighed shall be loaded into clean filter cassettes and the loaded cassettes shall be placed in a covered or sealed container before they are taken to the test cell for sampling.

8.2.3.10. Substitution weighing

Substitution weighing is an option and, if used, involves measurement of a reference weight before and after each weighing of a PM sampling medium (e.g. filter). While

substitution weighing requires more measurements, it corrects for a balance's zero-drift and it relies on balance linearity only over a small range. This is most appropriate when quantifying total PM masses that are less than 0,1 % of the sample medium's mass. However, it may not be appropriate when total PM masses exceed 1 % of the sample medium's mass. If substitution weighing is used, it shall be used for both pre-test and post-test weighing. The same substitution weight shall be used for both pre-test and post-test weighing. The mass of the substitution weight shall be corrected for buoyancy if the density of the substitution weight is less than 2,0 g/cm³. The following steps are an example of substitution weighing:

- (a) Electrically grounded tweezers or a grounding strap shall be used, as described in point 9.3.4.6.;
- (b) A static neutralizer shall be used as described in point 9.3.4.6. to minimize static electric charge on any object before it is placed on the balance pan;
- (c) A substitution weight shall be selected that meets the specifications for calibration weights in point 9.5.2.. The substitution weight shall also have the same density as the weight that is used to span the microbalance, and shall be similar in mass to an unused sample medium (e.g. filter). If filters are used, the weight's mass should be about (80 to 100) mg for typical 47 mm diameter filters;
- (d) The stable balance reading shall be recorded and then the calibration weight shall be removed;
- (e) An unused sampling medium (e.g. a new filter) shall be weighed, the stable balance reading recorded and the balance environment's dew point, ambient temperature, and atmospheric pressure recorded;
- (f) The calibration weight shall be reweighed and the stable balance reading recorded;
- (g) The arithmetic mean of the two calibration-weight readings that were recorded immediately before and after weighing the unused sample shall be calculated. That mean value shall be subtracted from the unused sample reading, then the true mass of the calibration weight as stated on the calibration-weight certificate shall be added. This result shall be recorded. This is the unused sample's tare weight without correcting for buoyancy;
- (h) These substitution-weighing steps shall be repeated for the remainder of the unused sample media;
- (i) The instructions given in points 8.2.3.7. to 8.2.3.9. shall be followed once weighing is completed.

8.2.4. Post-test PM sample conditioning and weighing

Used PM sample filters shall be placed into covered or sealed containers or the filter holders shall be closed, in order to protect the sample filters against ambient contamination. Thus protected, the loaded filters have to be returned to the PM-filter conditioning chamber or room. Then the PM sample filters shall be conditioned and weighted accordingly.

8.2.4.1. Periodic verification

It shall be assured that the weighing and PM-stabilization environments have met the periodic verifications in point 8.1.13.1.. After testing is complete, the filters shall be returned to the weighing and PM-stabilisation environment. The weighing and PM-stabilisation environment shall meet the ambient conditions requirements in point 9.3.4.4., otherwise the test filters shall be left covered until proper conditions have been met.

8.2.4.2. Removal from sealed containers

In the PM-stabilization environment, the PM samples shall be removed from the sealed containers. Filters may be removed from their cassettes before or after stabilization. When a filter is removed from a cassette, the top half of the cassette shall be separated from the bottom half using a cassette separator designed for this purpose.

8.2.4.3. Electrical grounding

To handle PM samples, electrically grounded tweezers or a grounding strap shall be used, as described in point 9.3.4.5..

8.2.4.4. Visual inspection

The collected PM samples and the associated filter media shall be inspected visually. If the conditions of either the filter or the collected PM sample appear to have been compromised, or if the particulate matter contacts any surface other than the filter, the sample may not be used to determine particulate emissions. In the case of contact with another surface; the affected surface shall be cleaned before proceeding.

8.2.4.5. Stabilisation of PM samples

To stabilise PM samples, they shall be placed in one or more containers that are open to the PM-stabilization environment, which is described in point 9.3.4.3.. A PM sample is stabilized as long as it has been in the PM-stabilization environment for one of the following durations, during which the stabilization environment has been within the specifications of point 9.3.4.3.:

- (a) If it is expected that a filter's total surface concentration of PM will be greater than $0,353 \mu\text{g}/\text{mm}^2$, assuming a $400 \mu\text{g}$ loading on a 38 mm diameter filter stain area, the filter shall be exposed to the stabilization environment for at least 60 minutes before weighing;

- (b) If it is expected that a filter's total surface concentration of PM will be less than $0,353 \mu\text{g}/\text{mm}^2$, the filter shall be exposed to the stabilization environment for at least 30 minutes before weighing;
- (c) If a filter's total surface concentration of PM to be expected during the test is unknown, the filter shall be exposed to the stabilization environment for at least 60 minutes before weighing.

8.2.4.6. Determination of post-test filter mass

The procedures in point 8.2.3. shall be repeated (points 8.2.3.6. through 8.2.3.9.) to determine the post-test filter mass.

8.2.4.7. Total mass

Each buoyancy-corrected filter tare mass shall be subtracted from its respective buoyancy-corrected post-test filter mass. The result is the total mass, m_{total} , which shall be used in emission calculations in Annex VII.

9. Measurement equipment

9.1. Engine dynamometer specification

9.1.1. Shaft work

An engine dynamometer shall be used that has adequate characteristics to perform the applicable duty cycle including the ability to meet appropriate cycle validation criteria. The following dynamometers may be used:

- (a) Eddy-current or water-brake dynamometers;
- (b) Alternating-current or direct-current motoring dynamometers;
- (c) One or more dynamometers.

9.1.2. Transient (NRTC and LSI-NRTC) test cycles

Load cell or in-line torque meter may be used for torque measurements.

When using a load cell, the torque signal shall be transferred to the engine axis and the inertia of the dynamometer shall be considered. The actual engine torque is the torque read on the load cell plus the moment of inertia of the brake multiplied by the angular acceleration. The control system has to perform such a calculation in real time.

9.1.3. Engine accessories

The work of engine accessories required to fuel, lubricate, or heat the engine, circulate liquid coolant to the engine, or to operate exhaust after-treatment systems shall be accounted for and they shall be installed in accordance with point 6.3..

9.1.4. Engine fixture and power transmission shaft system (category NRSh)

Where necessary for the proper testing of an engine of category NRSh, the engine fixture for the test bench and power transmission shaft system for connection to the dynamometer rotating system specified by the manufacturer shall be used.

9.2. Dilution procedure (if applicable)

9.2.1. Diluent conditions and background concentrations

Gaseous constituents may be measured raw or dilute whereas PM measurement generally requires dilution. Dilution may be accomplished by a full flow or partial flow dilution system. When dilution is applied then the exhaust gas may be diluted with ambient air, synthetic air, or nitrogen. For gaseous emissions measurement the diluent shall be at least 288 K (15 °C). For PM sampling the temperature of the diluent is specified in points 9.2.2. for CVS and 9.2.3. for PFD with varying dilution ratio. The flow capacity of the dilution system shall be large enough to completely eliminate water condensation in the dilution and sampling systems. De-humidifying the dilution air before entering the dilution system is permitted, if the air humidity is high. The dilution tunnel walls may be heated or insulated as well as the bulk stream tubing downstream of the tunnel to prevent the precipitation of water-containing constituents from a gas phase to a liquid phase ("aqueous condensation").

Before a diluent is mixed with exhaust gas, it may be preconditioned by increasing or decreasing its temperature or humidity. Constituents may be removed from the diluent to reduce their background concentrations. The following provisions apply to removing constituents or accounting for background concentrations:

- (a) Constituent concentrations in the diluent may be measured and compensated for background effects on test results. See Annex VII for calculations that compensate for background concentrations;
- (b) The following changes to the requirements of sections 7.2., 9.3. and 9.4. are permitted for measuring background gaseous or particulate pollutants:
 - (i) It shall not be required to use proportional sampling;
 - (ii) Unheated sampling systems may be used;
 - (iii) Continuous sampling may be used irrespective of the use of batch sampling for diluted emissions;
 - (iv) Batch sampling may be used irrespective of the use of continuous sampling for diluted emissions.
- (c) To account for background PM the following options are available:

- (i) For removing background PM, the diluent shall be filtered with high-efficiency particulate air (HEPA) filters that have an initial minimum collection efficiency specification of 99,97 % (see Article 2(19) for procedures related to HEPA-filtration efficiencies);
- (ii) For correcting for background PM without HEPA filtration, the background PM shall not contribute more than 50 % of the net PM collected on the sample filter;
- (iii) Background correction of net PM with HEPA filtration is permitted without pressure restriction.

9.2.2. Full flow system

Full-flow dilution; constant-volume sampling (CVS). The full flow of raw exhaust gas is diluted in a dilution tunnel. Constant flow may be maintained by maintaining the temperature and pressure at the flow meter within the limits. For non-constant flow the flow shall be measured directly to allow for proportional sampling. The system shall be designed as follows (see Figure 6.6.):

- (a) A tunnel with inside surfaces of stainless steel shall be used. The entire dilution tunnel shall be electrically grounded. Alternatively non-conductive materials may be used for engine categories neither subject to PM nor PN limits;
- (b) The exhaust gas back-pressure shall not be artificially lowered by the dilution air inlet system. The static pressure at the location where raw exhaust gas is introduced into the tunnel shall be maintained within $\pm 1,2$ kPa of atmospheric pressure;
- (c) To support mixing the raw exhaust gas shall be introduced into the tunnel by directing it downstream along the centreline of the tunnel. A fraction of dilution air maybe introduced radially from the tunnel's inner surface to minimize exhaust gas interaction with the tunnel walls;
- (d) Diluent. For PM sampling the temperature of the diluents (ambient air, synthetic air, or nitrogen as quoted in point 9.2.1.) shall be maintained between 293 and 325 K (20 to 52 °C) in close proximity to the entrance into the dilution tunnel;
- (e) The Reynolds number, Re , shall be at least 4000 for the diluted exhaust gas flow, where Re is based on the inside diameter of the dilution tunnel. Re is defined in Annex VII. Verification of adequate mixing shall be performed while traversing a sampling probe across the tunnel's diameter, vertically and horizontally. If the analyzer response indicates any deviation exceeding ± 2 % of the mean measured concentration, the CVS shall be operated at a higher flow rate or a mixing plate or orifice shall be installed to improve mixing;

- (f) Flow measurement preconditioning. The diluted exhaust gas may be conditioned before measuring its flow rate, as long as this conditioning takes place downstream of heated HC or PM sample probes, as follows:
 - (i) Flow straighteners, pulsation dampeners, or both of these maybe used;
 - (ii) A filter maybe used;
 - (iii) A heat exchanger maybe used to control the temperature upstream of any flow meter but steps shall be taken to prevent aqueous condensation;
- (g) Aqueous condensation. Aqueous condensation is a function of humidity, pressure, temperature, and concentrations of other constituents such as sulphuric acid. These parameters vary as a function of engine intake-air humidity, dilution-air humidity, engine air-to-fuel ratio, and fuel composition - including the amount of hydrogen and sulphur in the fuel.

To ensure that a flow is measured that corresponds to a measured concentration, either aqueous condensation shall be prevented between the sample probe location and the flow meter inlet in the dilution tunnel or aqueous condensation shall be allowed to occur and humidity at the flow meter inlet measured. The dilution tunnel walls or bulk stream tubing downstream of the tunnel may be heated or insulated to prevent aqueous condensation. Aqueous condensation shall be prevented throughout the dilution tunnel. Certain exhaust gas components can be diluted or eliminated by the presence of moisture;

For PM sampling, the already proportional flow coming from CVS goes through secondary dilution (one or more) to achieve the requested overall dilution ratio as shown in Figure 9.2. and set out in point 9.2.3.2.;

- (h) The minimum overall dilution ratio shall be within the range of 5:1 to 7:1 and at least 2:1 for the primary dilution stage based on the maximum engine exhaust gas flow rate during the test cycle or test interval;
- (i) The overall residence time in the system shall be between 0,5 and 5 seconds, as measured from the point of diluent introduction to the filter holder(s);
- (j) The residence time in the secondary dilution system, if present, shall be at least 0,5 seconds, as measured from the point of secondary diluent introduction to the filter holder(s).

To determine the mass of the particulates, a particulate sampling system, a particulate sampling filter, a gravimetric balance, and a temperature and humidity controlled weighing chamber, are required.

Figure 6.6.

Examples of full-flow dilution sampling configurations

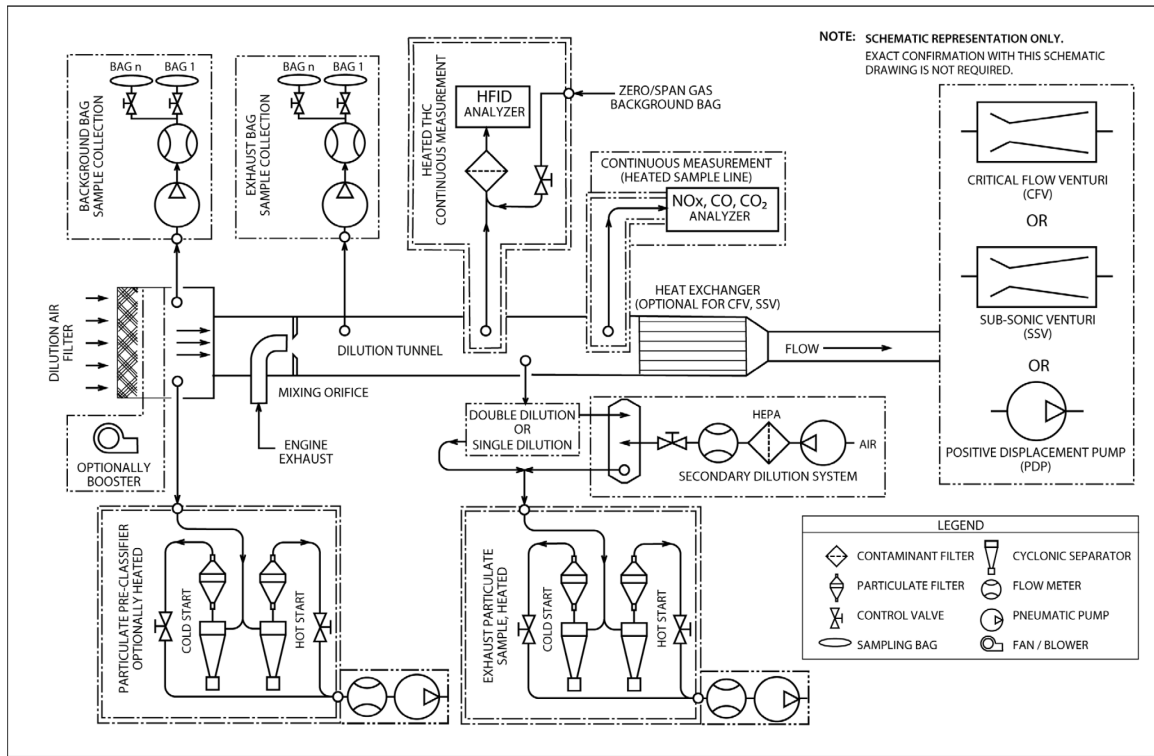

9.2.3. Partial flow dilution (PFD) system

9.2.3.1. Description of partial flow system

A schematic of a PFD system is shown in Figure 6.7.. It is a general schematic showing principles of sample extraction, dilution and PM sampling. It is not meant to indicate that all the components described in the Figure are necessary for other possible sampling systems that satisfy the intent of sample collection. Other configurations which do not match these schematics are allowed under the condition that they serve the same purpose of sample collection, dilution, and PM sampling. These need to satisfy other criteria such as in points 8.1.8.6. (periodic calibration) and 8.2.1.2. (validation) for varying dilution PFD, and point 8.1.4.5. as well as Table 8.2. (linearity verification) and point 8.1.8.5.7. (verification) for constant dilution PFD.

As shown in Figure 6.7., the raw exhaust gas or the primary diluted flow is transferred from the exhaust pipe EP or from CVS respectively to the dilution tunnel DT through the sampling probe SP and the transfer line TL. The total flow through the tunnel is adjusted with a flow controller and the sampling pump P of the particulate sampling system (PSS). For proportional raw exhaust gas sampling, the dilution air flow is

controlled by the flow controller FC1, which may use q_{mew} (exhaust gas mass flow rate on wet basis) or q_{maw} (intake air mass flow rate on wet basis) and q_{mf} (fuel mass flow rate) as command signals, for the desired exhaust gas split. The sample flow into the dilution tunnel DT is the difference of the total flow and the dilution air flow. The dilution air flow rate is measured with the flow measurement device FM1, the total flow rate with the flow measurement device of the particulate sampling system. The dilution ratio is calculated from these two flow rates. For sampling with a constant dilution ratio of raw or diluted exhaust gas versus exhaust gas flow (e.g.: secondary dilution for PM sampling), the dilution air flow rate is usually constant and controlled by the flow controller FC1 or dilution air pump.

The dilution air (ambient air, synthetic air, or nitrogen) shall be filtered with a high-efficiency PM air (HEPA) filter.

Figure 6.7.

Schematic of partial flow dilution system (total sampling type).

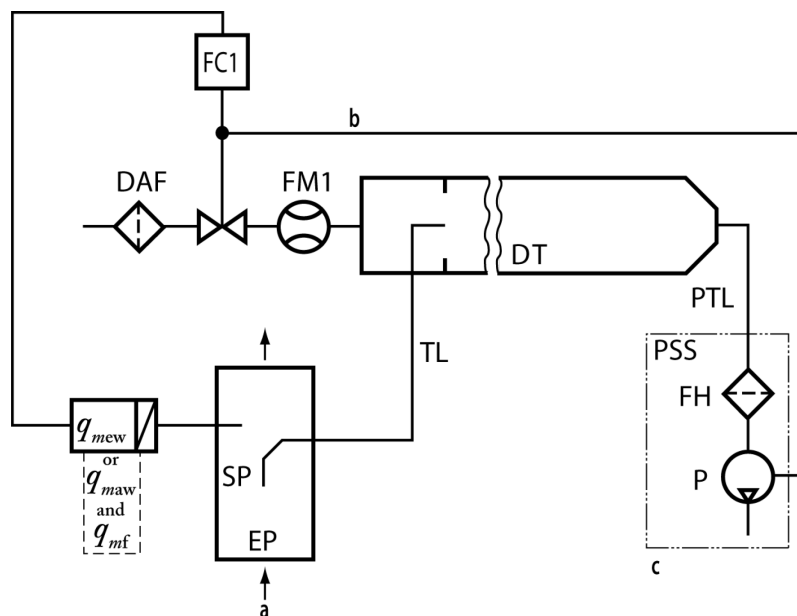

a = engine exhaust gas or primary diluted flow b = optional c = PM sampling

Components of Figure 6.7.:

DAF: Dilution air filter

DT: Dilution tunnel or secondary dilution system

EP: Exhaust pipe or primary dilution system

FC1: Flow controller
FH: Filter holder
FM1: Flow measurement device measuring the dilution air flow rate
P: Sampling pump
PSS: PM sampling system
PTL: PM transfer line
SP: Raw or diluted exhaust gas sampling probe
TL: Transfer line

Mass flow rates applicable only for proportional raw exhaust gas sampling PFD:

q_{mew} is the exhaust gas mass flow rate on wet basis

q_{maw} is the intake air mass flow rate on wet basis

q_{mf} is the fuel mass flow rate

9.2.3.2. Dilution

The temperature of the diluents (ambient air, synthetic air, or nitrogen as quoted in point 9.2.1.) shall be maintained between 293 and 325 K (20 to 52°C) in close proximity to the entrance into the dilution tunnel.

De-humidifying the dilution air before entering the dilution system is permitted. The partial flow dilution system has to be designed to extract a proportional raw exhaust gas sample from the engine exhaust gas stream, thus responding to excursions in the exhaust gas stream flow rate, and introduce dilution air to this sample to achieve a temperature at the test filter as prescribed by point 9.3.3.4.3.. For this it is essential that the dilution ratio be determined such that the accuracy requirements of point 8.1.8.6.1. are fulfilled.

To ensure that a flow is measured that corresponds to a measured concentration, either aqueous condensation shall be prevented between the sample probe location and the flow meter inlet in the dilution tunnel or aqueous condensation shall be allowed to occur and humidity at the flow meter inlet measured. The PFD system may be heated or insulated to prevent aqueous condensation. Aqueous condensation shall be prevented throughout the dilution tunnel.

The minimum dilution ratio shall be within the range of 5:1 to 7:1 based on the maximum engine exhaust gas flow rate during the test cycle or test interval.

The residence time in the system shall be between 0,5 and 5 s, as measured from the point of diluent introduction to the filter holder(s).

To determine the mass of the particulates, a particulate sampling system, a particulate sampling filter, a gravimetric balance, and a temperature and humidity controlled weighing chamber, are required.

9.2.3.3. Applicability

PFD may be used to extract a proportional raw exhaust gas sample for any batch or continuous PM and gaseous emission sampling over any transient (NRTC and LSI-NRTC) duty cycle, any discrete-mode NRSC or any RMC duty cycle.

The system may be used also for a previously diluted exhaust gas where, via a constant dilution-ratio, an already proportional flow is diluted (see Figure 9.2.). This is the way of performing secondary dilution from a CVS tunnel to achieve the necessary overall dilution ratio for PM sampling.

9.2.3.4. Calibration

The calibration of the PFD to extract a proportional raw exhaust gas sample is considered in point 8.1.8.6..

9.3. Sampling procedures

9.3.1. General sampling requirements

9.3.1.1. Probe design and construction

A probe is the first fitting in a sampling system. It protrudes into a raw or diluted exhaust gas stream to extract a sample, such that it's inside and outside surfaces are in contact with the exhaust gas. A sample is transported out of a probe into a transfer line.

Sample probes shall be made with inside surfaces of stainless steel or, for raw exhaust gas sampling, with any non-reactive material capable of withstanding raw exhaust gas temperatures. Sample probes shall be located where constituents are mixed to their mean sample concentration and where interference with other probes is minimised. It is recommended that all probes remain free from influences of boundary layers, wakes, and eddies – especially near the outlet of a raw-exhaust meter tailpipe where unintended dilution might occur. Purging or back-flushing of a probe shall not influence another probe during testing. A single probe to extract a sample of more than one constituent may be used as long as the probe meets all the specifications for each constituent.

9.3.1.1.1. Mixing chamber (category NRSh)

Where permitted by the manufacturer, a mixing chamber may be used when testing engines of category NRSh. The mixing chamber is an optional component of a raw gas sampling system and is located in the exhaust system between the silencer and the

sample probe. The shape and dimensions of the mixing chamber and tubing before and after shall be such that it provides a well-mixed, homogenous sample at the sample probe location and so that strong pulsations or resonances of the chamber influencing the emissions results are avoided.

9.3.1.2. Transfer lines

Transfer lines that transport an extracted sample from a probe to an analyzer, storage medium, or dilution system shall be minimized in length by locating analyzers, storage media, and dilution systems as close to the probes as practical. The number of bends in transfer lines shall be minimized and that the radius of any unavoidable bend shall be maximized.

9.3.1.3. Sampling methods

For continuous and batch sampling, introduced in point 7.2., the following conditions apply:

- (a) When extracting from a constant flow rate, the sample shall also be carried out at a constant flow rate;
- (b) When extracting from a varying flow rate, the sample flow rate shall be varied in proportion to the varying flow rate;
- (c) Proportional sampling shall be validated as described in point 8.2.1..

9.3.2. Gas sampling

9.3.2.1. Sampling probes

Either single-port or multi-port probes are used for sampling gaseous emissions. The probes may be oriented in any direction relative to the raw or diluted exhaust gas flow. For some probes, the sample temperatures shall be controlled, as follows:

- (a) For probes that extract NO_x from diluted exhaust gas, the probe's wall temperature shall be controlled to prevent aqueous condensation;
- (b) For probes that extract hydrocarbons from the diluted exhaust gas, a probe wall temperature is recommended to be controlled approximately 191 °C to minimise contamination.

9.3.2.1.1. Mixing chamber (Category NRSh)

When used in accordance with point 9.3.1.1.1., the internal volume of the mixing chamber shall not be less than ten times the cylinder displacement of the engine under test. The mixing chamber shall be coupled as closely as possible to the engine silencer and shall have a minimum inner surface temperature of 452 K (179 °C). The manufacturer may specify the design of the mixing chamber.

9.3.2.2. Transfer lines

Transfer lines with inside surfaces of stainless steel, PTFE, Viton™, or any other material that has better properties for emission sampling shall be used. A non-reactive material capable of withstanding exhaust gas temperatures shall be used. In-line filters may be used if the filter and its housing meet the same temperature requirements as the transfer lines, as follows:

- (a) For NO_x transfer lines upstream of either an NO₂-to-NO converter that meets the specifications set out in point 8.1.11.5. or a chiller that meets the specifications set out in point 8.1.11.4. a sample temperature that prevents aqueous condensation shall be maintained;
- (b) For THC transfer lines a wall temperature tolerance throughout the entire line of (191 ±11) °C shall be maintained. If sampled from raw exhaust gas, an unheated, insulated transfer line may be connected directly to a probe. The length and insulation of the transfer line shall be designed to cool the highest expected raw exhaust gas temperature to no lower than 191 °C, as measured at the transfer line outlet. For dilute sampling a transition zone between the probe and transfer line of up to 0,92 m in length is allowed to transition the wall temperature to (191 ±11) °C.

9.3.2.3. Sample-conditioning components

9.3.2.3.1. Sample dryers

9.3.2.3.1.1. Requirements

Sample dryers may be used for removing moisture from the sample in order to decrease the effect of water on gaseous emissions measurement. Sample dryers shall meet the requirements set out in point 9.3.2.3.1.1. and in point 9.3.2.3.1.2.. The moisture content 0,8 volume % is used in equation (7-13).

For the highest expected water vapour concentration H_m , the water removal technique shall maintain humidity at ≤ 5 g water/kg dry air (or about 0,8 volume % H₂O), which is 100 % relative humidity at 277.1 K (3,9 °C) and 101,3 kPa. This humidity specification is equivalent to about 25 % relative humidity at 298 K (25 °C) and 101,3 kPa. This may be demonstrated by

- (a) measuring the temperature at the outlet of the sample dryer;
- (b) measuring humidity at a point just upstream of the CLD;

performing the verification procedure in point 8.1.8.5.8..

9.3.2.3.1.2. Type of sample dryers allowed and procedure to estimate moisture content after the dryer

Either type of sample dryer described in this point may be used.

- (a) If an osmotic-membrane dryer upstream of any gaseous analyzer or storage medium is used, it shall meet the temperature specifications set out in point 9.3.2.2.. The dew point, T_{dew} , and absolute pressure, p_{total} , downstream of an osmotic-membrane dryer shall be monitored. The amount of water shall be calculated as specified in Annex VII by using continuously recorded values of T_{dew} and p_{total} or their peak values observed during a test or their alarm set points. Lacking a direct measurement, the nominal p_{total} is given by the dryer's lowest absolute pressure expected during testing.
- (b) A thermal chiller upstream of a THC measurement system for compression-ignition engines may not be used. If a thermal chiller upstream of an NO₂-to-NO converter or in a sampling system without an NO₂-to-NO converter is used, the chiller shall meet the NO₂ loss-performance check specified in point 8.1.11.4.. The dew point, T_{dew} , and absolute pressure, p_{total} , downstream of a thermal chiller shall be monitored. The amount of water shall be calculated as specified in Annex VII by using continuously recorded values of T_{dew} and p_{total} or their peak values observed during a test or their alarm set points. Lacking a direct measurement, the nominal p_{total} is given by the thermal chiller's lowest absolute pressure expected during testing. If it is valid to assume the degree of saturation in the thermal chiller, T_{dew} based on the known chiller efficiency and continuous monitoring of chiller temperature, T_{chiller} may be calculated. If values of T_{chiller} are not continuously recorded, its peak value observed during a test, or its alarm set point, may be used as a constant value to determine a constant amount of water in accordance with Annex VII. If it is valid to assume that T_{chiller} is equal to T_{dew} , T_{chiller} may be used in lieu of T_{dew} in accordance with Annex VII. If it is valid to assume a constant temperature offset between T_{chiller} and T_{dew} , due to a known and fixed amount of sample reheat between the chiller outlet and the temperature measurement location, this assumed temperature offset value may be factored in into emission calculations. The validity of any assumptions allowed by this point shall be shown by engineering analysis or by data.

9.3.2.3.2. Sample pumps

Sample pumps upstream of an analyzer or storage medium for any gas shall be used. Sample pumps with inside surfaces of stainless steel, PTFE, or any other material having better properties for emission sampling shall be used. For some sample pumps, temperatures shall be controlled, as follows:

- (a) If a NO_x sample pump upstream of either an NO₂-to-NO converter that meets the requirements set out in point 8.1.11.5. or a chiller that meets the requirements set out in point 8.1.11.4. is used, it shall be heated to prevent aqueous condensation;
- (b) If a THC sample pump upstream of a THC analyzer or storage medium is used, its inner surfaces shall be heated to a tolerance of 464 ± 11 K (191 ± 11) °C.

9.3.2.3.3. Ammonia scrubbers

Ammonia scrubbers may be used for any or all gaseous sampling systems to prevent NH₃ interference, poisoning of NO₂-to-NO converter, and deposits in the sampling system or analysers. Installation of the ammonia scrubber shall follow the manufacturer's recommendations.

9.3.2.4. Sample storage media

In the case of bag sampling, gas volumes shall be stored in sufficiently clean containers that minimally off-gas or allow permeation of gases. Good engineering judgment shall be used to determine acceptable thresholds of storage media cleanliness and permeation. To clean a container, it may be repeatedly purged and evacuated and may be heated. A flexible container (such as a bag) within a temperature-controlled environment, or a temperature controlled rigid container that is initially evacuated or has a volume that can be displaced, such as a piston and cylinder arrangement, shall be used. Containers meeting the specifications in the following Table 6.6. shall be used.

Table 6.6.

Gaseous Batch Sampling Container Materials

CO, CO ₂ , O ₂ , CH ₄ , C ₂ H ₆ , C ₃ H ₈ , NO, NO ₂ ¹	polyvinyl fluoride (PVF) ² for example Tedlar TM , polyvinylidene fluoride ² for example Kynar TM , polytetrafluoroethylene ³ for example Teflon TM , or stainless steel ³
HC	polytetrafluoroethylene ⁴ or stainless steel ⁴

¹ As long as aqueous condensation in storage container is prevented.

² Up to 313 K (40 °C).

³ Up to 475 K (202 °C).

⁴ At 464 ± 11 K (191 ± 11 °C).

9.3.3. PM sampling

9.3.3.1. Sampling probes

PM probes with a single opening at the end shall be used. PM probes shall be oriented to face directly upstream.

The PM probe may be shielded with a hat that conforms with the requirements in Figure 6.8. In this case the pre-classifier described in point 9.3.3.3. shall not be used.

Figure 6.8.

Scheme of a sampling probe with a hat-shaped pre-classifier

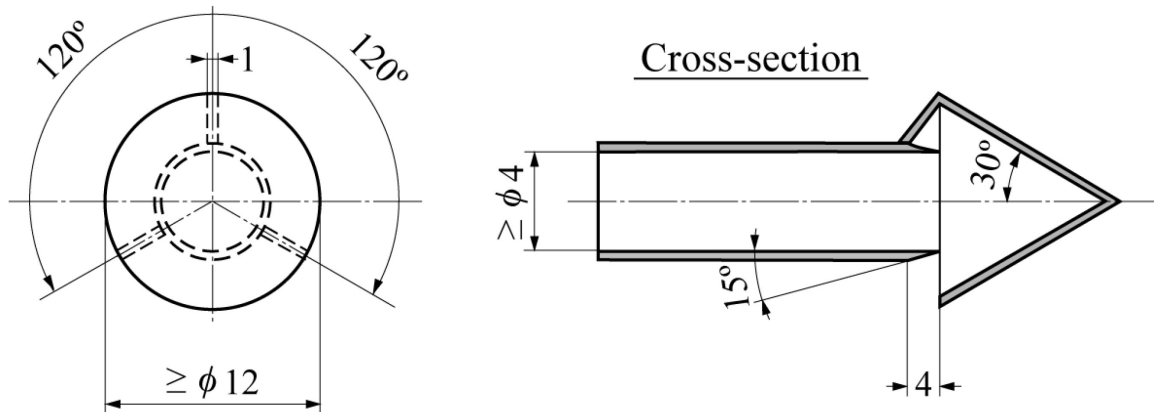

9.3.3.2. Transfer lines

Insulated or heated transfer lines or a heated enclosure are recommended to minimize temperature differences between transfer lines and exhaust gas constituents. Transfer lines that are inert with respect to PM and are electrically conductive on the inside surfaces shall be used. It is recommended using PM transfer lines made of stainless steel; any material other than stainless steel will be required to meet the same sampling performance as stainless steel. The inside surface of PM transfer lines shall be electrically grounded.

9.3.3.3. Pre-classifier

The use of a PM pre-classifier to remove large-diameter particles is permitted that is installed in the dilution system directly before the filter holder. Only one pre-classifier is permitted. If a hat shaped probe is used (see Figure 6.8.), the use of a pre-classifier is prohibited.

The PM pre-classifier may be either an inertial impactor or a cyclonic separator. It shall be constructed of stainless steel. The pre-classifier shall be rated to remove at least 50 % of PM at an aerodynamic diameter of 10 μm and no more than 1 % of PM at an aerodynamic diameter of 1 μm over the range of flow rates for which it is used. The pre-classifier outlet shall be configured with a means of bypassing any PM sample filter so that the pre-classifier flow can be stabilized before starting a test. PM sample filter shall be located within 75 cm downstream of the pre-classifier's exit.

9.3.3.4. Sample filter

The diluted exhaust gas shall be sampled by a filter that meets the requirements set out in points 9.3.3.4.1. to 9.3.3.4.4. during the test sequence.

9.3.3.4.1. Filter specification

All filter types shall have a collection efficiency of at least 99,7 %. The sample filter manufacturer's measurements reflected in their product ratings may be used to show this requirement. The filter material shall be either:

- (a) Fluorocarbon (PTFE) coated glass fibre; or
- (b) Fluorocarbon (PTFE) membrane.

If the expected net PM mass on the filter exceeds 400 µg, a filter with a minimum initial collection efficiency of 98 % may be used.

9.3.3.4.2. Filter size

The nominal filter size shall be 46,50 mm ± 0,6 mm diameter (at least 37 mm stain diameter). Larger diameter filters may be used with prior agreement of the approval authority. Proportionality between filter and stain area is recommended.

9.3.3.4.3. Dilution and temperature control of PM samples

PM samples shall be diluted at least once upstream of transfer lines in case of a CVS system and downstream in case of PFD system (see point 9.3.3.2. relating to transfer lines). Sample temperature shall be controlled to a 320 ± 5 K (47 ± 5 °C) tolerance, as measured anywhere within 200 mm upstream or 200 mm downstream of the PM storage media. The PM sample is intended to be heated or cooled primarily by dilution conditions as specified in point 9.2.1.(a).

9.3.3.4.4. Filter face velocity

A filter face velocity shall be between 0,90 and 1,00 m/s with less than 5 % of the recorded flow values exceeding this range. If the total PM mass exceeds 400 µg, the filter face velocity may be reduced. The face velocity shall be measured as the volumetric flow rate of the sample at the pressure upstream of the filter and temperature of the filter face, divided by the filter's exposed area. The exhaust system stack or CVS tunnel pressure shall be used for the upstream pressure if the pressure drop through the PM sampler up to the filter is less than 2 kPa.

9.3.3.4.5. Filter holder

To minimize turbulent deposition and to deposit PM evenly on a filter, a 12,5° (from centre) divergent cone angle to transition from the transfer-line inside diameter to the exposed diameter of the filter face shall be used. Stainless steel for this transition shall be used.

9.3.4. PM-stabilization and weighing environments for gravimetric analysis

9.3.4.1. Environment for gravimetric analysis

This section describes the two environments required to stabilize and weigh PM for gravimetric analysis: the PM stabilization environment, where filters are stored before weighing; and the weighing environment, where the balance is located. The two environments may share a common space.

Both the stabilization and the weighing environments shall be kept free of ambient contaminants, such as dust, aerosols, or semi-volatile material that could contaminate PM samples.

9.3.4.2. Cleanliness

The cleanliness of the PM-stabilization environment using reference filters shall be verified, as described in point 8.1.12.1.4..

9.3.4.3. Temperature of the chamber

The temperature of the chamber (or room) in which the particulate filters are conditioned and weighed shall be maintained to within 295 ± 1 K ($22 \text{ °C} \pm 1 \text{ °C}$) during all filter conditioning and weighing. The humidity shall be maintained to a dew point of $282,5 \pm 1$ K ($9,5 \text{ °C} \pm 1 \text{ °C}$) and a relative humidity of $45 \% \pm 8 \%$. If the stabilization and weighing environments are separate, the stabilization environment shall be maintained at a tolerance of 295 ± 3 K ($22 \text{ °C} \pm 3 \text{ °C}$).

9.3.4.4. Verification of ambient conditions

When using measurement instruments that meet the specifications in point 9.4. the following ambient conditions shall be verified:

- (a) Dew point and ambient temperature shall be recorded. These values shall be used to determine if the stabilization and weighing environments have remained within the tolerances specified in point 9.3.4.3. for at least 60 min before weighing filters;
- (b) Atmospheric pressure shall be continuously recorded within the weighing environment. An acceptable alternative is to use a barometer that measures atmospheric pressure outside the weighing environment, as long as it can be ensured that the atmospheric pressure at the balance is always at the balance within ± 100 Pa of the shared atmospheric pressure. A means to record the most recent atmospheric pressure shall be provided when each PM sample is weighed. This value shall be used to calculate the PM buoyancy correction in point 8.1.12.2..

9.3.4.5. Installation of balance

The balance shall be installed as follows:

- (a) Installed on a vibration-isolation platform to isolate it from external noise and vibration;

- (b) Shielded from convective airflow with a static-dissipating draft shield that is electrically grounded.

9.3.4.6. Static electric charge

Static electric charge shall be minimized in the balance environment, as follows:

- (a) The balance is electrically grounded;
- (b) Stainless steel tweezers shall be used if PM samples shall be handled manually;
- (c) Tweezers shall be grounded with a grounding strap, or a grounding strap shall be provided for the operator such that the grounding strap shares a common ground with the balance;
- (d) A static-electricity neutralizer shall be provided that is electrically grounded in common with the balance to remove static charge from PM samples.

9.4. Measurement instruments

9.4.1. Introduction

9.4.1.1. Scope

This point specifies measurement instruments and associated system requirements related to emission testing. This includes laboratory instruments for measuring engine parameters, ambient conditions, flow-related parameters, and emission concentrations (raw or diluted).

9.4.1.2. Instrument types

Any instrument mentioned in this Regulation shall be used as described in the Regulation itself (see Table 6.5. for measurement quantities provided by these instruments). Whenever an instrument mentioned in this Regulation is used in a way that is not specified, or another instrument is used in its place, the requirements for equivalency provisions shall apply as specified in point 5.1.1.. Where more than one instrument for a particular measurement is specified, one of them will be identified by the type approval or certifying authority upon application as the reference for showing that an alternative procedure is equivalent to the specified procedure.

9.4.1.3. Redundant systems

Data from multiple instruments to calculate test results for a single test may be used for all measurement instruments described in this point, with prior approval of the type approval or certification authority. Results from all measurements shall be recorded and the raw data shall be retained. This requirement applies whether or not the measurements are actually used in the calculations.

9.4.2. Data recording and control

The test system shall be able to update data, record data and control systems related to operator demand, the dynamometer, sampling equipment, and measurement instruments. Data acquisition and control systems shall be used that can record at the specified minimum frequencies, as shown in Table 6.7. (this Table does not apply to discrete-mode NRSC testing).

Table 6.7.

Data recording and control minimum frequencies

Applicable Test Protocol Section	Measured Values	Minimum Command and Control Frequency	Minimum Recording Frequency
7.6.	Speed and torque during an engine step-map	1 Hz	1 mean value per step
7.6.	Speed and torque during an engine sweep-map	5 Hz	1 Hz means
7.8.3.	Transient (NRTC and LSI-NRTC) duty cycle reference and feedback speeds and torques	5 Hz	1 Hz means
7.8.2.	Discrete-mode NRSC and RMC duty cycle reference and feedback speeds and torques	1 Hz	1 Hz
7.3.	Continuous concentrations of raw analyzers	N/A	1 Hz
7.3.	Continuous concentrations of dilute analyzers	N/A	1 Hz
7.3.	Batch concentrations of raw or dilute analyzers	N/A	1 mean value per test interval
7.6. 8.2.1.	Diluted exhaust gas flow rate from a CVS with a heat exchanger upstream of the flow measurement	N/A	1 Hz
7.6. 8.2.1.	Diluted exhaust gas flow rate from a CVS without a heat exchanger upstream of the flow measurement	5 Hz	1 Hz means
7.6. 8.2.1.	Intake-air or exhaust gas flow rate (for raw transient measurement)	N/A	1 Hz means
7.6. 8.2.1.	Dilution air if actively controlled	5 Hz	1 Hz means
7.6. 8.2.1.	Sample flow from a CVS with a heat exchanger	1 Hz	1 Hz
7.6. 8.2.1.	Sample flow from a CVS without a heat exchanger	5 Hz	1 Hz mean

9.4.3. Performance specifications for measurement instruments

9.4.3.1. Overview

The test system as a whole shall meet all the applicable calibrations, verifications, and test-validation criteria specified in point 8.1., including the requirements of the linearity check of points 8.1.4. and 8.2.. Instruments shall meet the specifications in Table 6.7.

for all ranges to be used for testing. Furthermore, any documentation received from instrument manufacturers showing that instruments meet the specifications in Table 6.7. shall be kept.

9.4.3.2. Component requirements

Table 6.8. shows the specifications of transducers of torque, speed, and pressure, sensors of temperature and dew point, and other instruments. The overall system for measuring the given physical and/or chemical quantity shall meet the linearity verification in point 8.1.4.. For gaseous emissions measurements, analyzers may be used, that have compensation algorithms that are functions of other measured gaseous components, and of the fuel properties for the specific engine test. Any compensation algorithm shall only provide offset compensation without affecting any gain (that is no bias).

Table 6.8.

Recommended performance specifications for measurement instruments

Measurement Instrument	Measured quantity symbol	Complete System Rise time	Recording update frequency	Accuracy ^(a)	Repeatability ^(a)
Engine speed transducer	<i>n</i>	1 s	1 Hz means	2,0 % of pt. or 0,5 % of max	1,0 % of pt. or 0,25 % of max
Engine torque transducer	<i>T</i>	1 s	1 Hz means	2,0 % of pt. or 1,0 % of max	1,0 % of pt. or 0,5 % of max
Fuel flow meter (Fuel totalizer)		5 s (N/A)	1 Hz (N/A)	2,0 % of pt. or 1,5 % of max	1,0 % of pt. or 0,75 % of max
Total diluted exhaust gas meter (CVS) (With heat exchanger before meter)		1 s (5 s)	1 Hz means (1 Hz)	2,0 % of pt. or 1,5 % of max	1,0 % of pt. or 0,75 % of max
Dilution air, inlet air, exhaust gas, and sample flow meters		1 s	1 Hz means of 5 Hz samples	2,5 % of pt. or 1,5 % of max	1,25 % of pt. or 0,75 % of max
Continuous gas analyzer raw	<i>X</i>	5 s	2 Hz	2,0 % of pt. or 2,0 % of meas.	1,0 % of pt. or 1,0 % of meas.
Continuous gas analyzer dilute	<i>X</i>	5 s	1 Hz	2,0 % of pt. or 2,0 % of meas.	1,0 % of pt. or 1,0 % of meas.
Continuous gas analyzer	<i>X</i>	5 s	1 Hz	2,0 % of pt. or 2,0 % of meas.	1,0 % of pt. or 1,0 % of meas.
Batch gas analyzer	<i>X</i>	N/A	N/A	2,0 % of pt. or 2,0 % of meas.	1,0 % of pt. or 1,0 % of meas.
Gravimetric PM balance	<i>m_{PM}</i>	N/A	N/A	See 9.4.11.	0,5 µg
Inertial PM balance	<i>m_{PM}</i>	5 s	1 Hz	2,0 % of pt. or 2,0 % of meas.	1,0 % of pt. or 1,0 % of meas.

^(a) Accuracy and repeatability are all determined with the same collected data, as described in §9.4.3., and based on absolute values. "pt." refers to the overall mean value expected at the emission limit ; "max." refers to the peak value expected at the emission limit over the duty cycle , not the maximum of the instrument's range; "meas." refers to the actual mean measured over the duty cycle .

9.4.4. Measurement of engine parameters & ambient conditions

9.4.4.1. Speed and torque sensors

9.4.4.1.1. Application

Measurement instruments for work inputs and outputs during engine operation shall meet the specifications in this point. Sensors, transducers, and meters meeting the specifications in Table 6.8. are recommended. Overall systems for measuring work inputs and outputs shall meet the linearity verifications in point 8.1.4..

9.4.4.1.2. Shaft work

Work and power shall be calculated from outputs of speed and torque transducers according to point 9.4.4.1.. Overall systems for measuring speed and torque shall meet the calibration and verifications in points 8.1.7. and 8.1.4..

Torque induced by the inertia of accelerating and decelerating components connected to the flywheel, such as the drive shaft and dynamometer rotor, shall be compensated for as needed, based on good engineering judgment.

9.4.4.2. Pressure transducers, temperature sensors, and dew point sensors

Overall systems for measuring pressure, temperature, and dew point shall meet the calibration in point 8.1.7..

Pressure transducers shall be located in a temperature-controlled environment, or they shall compensate for temperature changes over their expected operating range. Transducer materials shall be compatible with the fluid being measured.

9.4.5. Flow-related measurements

For any type of flow meter (of fuel, intake-air, raw exhaust gas, diluted exhaust gas, sample), the flow shall be conditioned as needed to prevent wakes, eddies, circulating flows, or flow pulsations from affecting the accuracy or repeatability of the meter. For some meters, this may be accomplished by using a sufficient length of straight tubing (such as a length equal to at least 10 pipe diameters) or by using specially designed tubing bends, straightening fins, orifice plates (or pneumatic pulsation dampeners for the fuel flow meter) to establish a steady and predictable velocity profile upstream of the meter.

9.4.5.1. Fuel flow meter

Overall system for measuring fuel flow shall meet the calibration in point 8.1.8.1. In any fuel flow measurement it shall be accounted for any fuel that bypasses the engine or returns from the engine to the fuel storage tank.

9.4.5.2. Intake-air flow meter

Overall system for measuring intake-air flow shall meet the calibration in point 8.1.8.2..

9.4.5.3. Raw exhaust flow meter

9.4.5.3.1. Component requirements

The overall system for measuring raw exhaust gas flow shall meet the linearity requirements in point 8.1.4.. Any raw-exhaust meter shall be designed to appropriately compensate for changes in the raw exhaust gas' thermodynamic, fluid, and compositional states.

9.4.5.3.2. Flow meter response time

For the purpose of controlling of a partial flow dilution system to extract a proportional raw exhaust gas sample, a flow meter response time faster than indicated in Table 9.3. is required. For partial flow dilution systems with online control, the flow meter response time shall meet the specifications of point 8.2.1.2..

9.4.5.3.3. Exhaust gas cooling

This point does not apply to cooling of the exhaust gas due to the design of the engine, including, but not limited to, water-cooled exhaust manifolds or turbochargers.

Exhaust gas cooling upstream of the flow meter is permitted with the following restrictions:

- (a) PM shall not be sampled downstream of the cooling;
- (b) If cooling causes exhaust gas temperatures above 475 K (202 °C) to decrease to below 453 K (180 °C), HC shall not be sampled downstream of the cooling;
- (c) If cooling causes aqueous condensation, NO_x shall not be sampled downstream of the cooling unless the cooler meets the performance verification in point 8.1.11.4.;
- (d) If cooling causes aqueous condensation before the flow reaches a flow meter, dew point T_{dew} and pressure p_{total} shall be measured at the flow meter inlet. These values shall be used in emission calculations in accordance with Annex VII.

9.4.5.4. Dilution air and diluted exhaust flow meters

9.4.5.4.1. Application

Instantaneous diluted exhaust gas flow rates or total diluted exhaust gas flow over a test interval shall be determined by using a diluted exhaust flow meter. Raw exhaust gas flow rates or total raw exhaust gas flow over a test interval may be calculated from the difference between a diluted exhaust flow meter and a dilution air meter.

9.4.5.4.2. Component requirements

The overall system for measuring diluted exhaust gas flow shall meet the calibration and verifications in points 8.1.8.4. and 8.1.8.5.. The following meters may be used:

- (a) For constant-volume sampling (CVS) of the total flow of diluted exhaust gas, a critical-flow venturi (CFV) or multiple critical-flow venturis arranged in parallel, a positive-displacement pump (PDP), a subsonic venturi (SSV), or an ultrasonic flow meter (UFM) may be used. Combined with an upstream heat exchanger, either a CFV or a PDP will also function as a passive flow controller by keeping the diluted exhaust gas temperature constant in a CVS system;
- (b) For the Partial Flow Dilution (PFD) system the combination of any flow meter with any active flow control system to maintain proportional sampling of exhaust gas constituents may be used. The total flow of diluted exhaust gas, or one or more sample flows, or a combination of these flow controls may be controlled to maintain proportional sampling.

For any other dilution system, a laminar flow element, an ultrasonic flow meter, a subsonic venturi, a critical-flow venturi or multiple critical-flow venturis arranged in parallel, a positive-displacement meter, a thermal-mass meter, an averaging Pitot tube, or a hot-wire anemometer may be used.

9.4.5.4.3. Exhaust gas cooling

Diluted exhaust gas upstream of a dilute flow meter may be cooled, as long as all the following provisions are observed:

- (a) PM shall not be sampled downstream of the cooling;
- (b) If cooling causes exhaust gas temperatures above 475 K (202 °C) to decrease to below 453 K (180 °C), HC shall not be sampled downstream of the cooling;
- (c) If cooling causes aqueous condensation, NO_x shall not be sampled downstream of the cooling unless the cooler meets the performance verification in point 8.1.11.4.;
- (d) If cooling causes aqueous condensation before the flow reaches a flow meter, dew point, T_{dew} and pressure p_{total} shall be measured at the flow meter inlet. These values shall be used in emission calculations in accordance with Annex VII.

9.4.5.5. Sample flow meter for batch sampling

A sample flow meter shall be used to determine sample flow rates or total flow sampled into a batch sampling system over a test interval. The difference between two flow meters may be used to calculate sample flow into a dilution tunnel e.g. for partial flow dilution PM measurement and secondary dilution flow PM measurement. Specifications for differential flow measurement to extract a proportional raw exhaust gas sample is set out in point 8.1.8.6.1. and the calibration of differential flow measurement is given in point 8.1.8.6.2..

Overall system for the sample flow meter shall meet the calibration requirements set out in point 8.1.8..

9.4.5.6. Gas divider

A gas divider may be used to blend calibration gases.

A gas divider shall be used that blends gases to the specifications of point 9.5.1. and to the concentrations expected during testing. Critical-flow gas dividers, capillary-tube gas dividers, or thermal-mass-meter gas dividers may be used. Viscosity corrections shall be applied as necessary (if not done by gas divider internal software) to appropriately ensure correct gas division. The gas-divider system shall meet the linearity verification set out in point 8.1.4.5.. Optionally, the blending device may be checked with an instrument which by nature is linear, e.g. using NO gas with a CLD. The span value of the instrument shall be adjusted with the span gas directly connected to the instrument. The gas divider shall be checked at the settings used and the nominal value shall be compared to the measured concentration of the instrument.

9.4.6. CO and CO₂ measurements

A Non-dispersive infrared (NDIR) analyzer shall be used to measure CO and CO₂ concentrations in raw or diluted exhaust gas for either batch or continuous sampling.

The NDIR-based system shall meet the calibration and verifications set out in point 8.1.8.1..

9.4.7. Hydrocarbon measurements

9.4.7.1. Flame-ionization detector

9.4.7.1.1. Application

A heated flame-ionization detector (HFID) analyzer shall be used to measure hydrocarbon concentrations in raw or diluted exhaust gas for either batch or continuous sampling. Hydrocarbon concentrations shall be determined on a carbon number basis of one, C₁. Heated FID analyzers shall maintain all surfaces that are exposed to emissions at a temperature of 464 ± 11 K (191 ± 11 °C). Optionally, for NG and LPG fuelled and SI engines, the hydrocarbon analyzer may be of the non-heated flame ionization detector (FID) type.

9.4.7.1.2. Component requirements

The FID-based system for measuring THC shall meet all of the verifications for hydrocarbon measurement in point 8.1.10..

9.4.7.1.3. FID fuel and burner air

FID fuel and burner air shall meet the specifications of point 9.5.1. The FID fuel and burner air shall not mix before entering the FID analyzer to ensure that the FID analyzer operates with a diffusion flame and not a premixed flame.

9.4.7.1.4. Reserved

9.4.7.1.5. Reserved

9.4.7.2. Reserved

9.4.8. NO_x measurements

Two measurement instruments are specified for NO_x measurement and either instrument may be used provided it meets the criteria specified in point 9.4.8.1. or 9.4.8.2., respectively. The chemiluminescent detector shall be used as the reference procedure for comparison with any proposed alternate measurement procedure under point 5.1.1..

9.4.8.1. Chemiluminescent detector

9.4.8.1.1. Application

A chemiluminescent detector (CLD) coupled with an NO₂-to-NO converter is used to measure NO_x concentration in raw or diluted exhaust gas for batch or continuous sampling.

9.4.8.1.2. Component requirements

The CLD-based system shall meet the quench verification set out in point 8.1.11.1.. A heated or unheated CLD may be used, and a CLD that operates at atmospheric pressure or under a vacuum may be used.

9.4.8.1.3. NO₂-to-NO converter

An internal or external NO₂-to-NO converter that meets the verification in point 8.1.11.5. shall be placed upstream of the CLD, while the converter shall be configured with a bypass to facilitate this verification.

9.4.8.1.4. Humidity effects

All CLD temperatures shall be maintained to prevent aqueous condensation. To remove humidity from a sample upstream of a CLD, one of the following configurations shall be used:

- (a) A CLD connected downstream of any dryer or chiller that is downstream of an NO₂-to-NO converter that meets the verification set out in point 8.1.11.5.;
- (b) A CLD connected downstream of any dryer or thermal chiller that meets the verification set out in point 8.1.11.4..

9.4.8.1.5. Response time

A heated CLD may be used to improve CLD response time.

9.4.8.2. Non-dispersive ultraviolet analyzer

9.4.8.2.1. Application

A non-dispersive ultraviolet (NDUV) analyzer is used to measure NO_x concentration in raw or diluted exhaust gas for batch or continuous sampling.

9.4.8.2.2. Component requirements

The NDUV-based system shall meet the verifications set out in point 8.1.11.3..

9.4.8.2.3. NO_2 -to-NO converter

If the NDUV analyzer measures only NO , an internal or external NO_2 -to-NO converter that meets the verification set out in point 8.1.11.5. shall be placed upstream of the NDUV analyzer. The converter shall be configured with a bypass to facilitate this verification.

9.4.8.2.4. Humidity effects

The NDUV temperature shall be maintained to prevent aqueous condensation, unless one of the following configurations is used:

- (a) An NDUV shall be connected downstream of any dryer or chiller that is downstream of an NO_2 -to-NO converter that meets the verification in point 8.1.11.5.;
- (b) An NDUV shall be connected downstream of any dryer or thermal chiller that meets the verification in point 8.1.11.4..

9.4.9. O_2 measurements

A paramagnetic detection (PMD) or magneto pneumatic detection (MPD) analyzer shall be used to measure O_2 concentration in raw or diluted exhaust gas for batch or continuous sampling.

9.4.10. Air-to-fuel ratio measurements

A Zirconia (ZrO_2) analyser may be used to measure air-to-fuel ratio in raw exhaust gas for continuous sampling. O_2 measurements with intake air or fuel flow measurements may be used to calculate exhaust gas flow rate in accordance with Annex VII.

9.4.11. PM measurements with gravimetric balance

A balance shall be used to weigh net PM collected on sample filter media.

The minimum requirement on the balance resolution shall be equal or lower than the repeatability of 0,5 microgram recommended in Table 6.8.. If the balance uses internal calibration weights for routine spanning and linearity verifications, the calibration weights shall meet the specifications in point 9.5.2..

The balance shall be configured for optimum settling time and stability at its location.

9.4.12. Ammonia (NH₃) measurements

A FTIR (Fourier transform infrared) analyser, NDUV or laser infrared analyser may be used in accordance with the instrument supplier's instructions.

9.5. Analytical gases and mass standards

9.5.1. Analytical gases

Analytical gases shall meet the accuracy and purity specifications of this section.

9.5.1.1. Gas specifications

The following gas specifications shall be considered:

- (a) Purified gases shall be used to blend with calibration gases and to adjust measurement instruments so as to obtain a zero response to a zero calibration standard. Gases with contamination no higher than the highest of the following values in the gas cylinder or at the outlet of a zero-gas generator shall be used:
 - (i) 2 % contamination, measured relative to the mean concentration expected at the standard. For example, if a CO concentration of 100,0 µmol/mol is expected, then it would be allowed to use a zero gas with CO contamination less than or equal to 2,000 µmol/mol;
 - (ii) Contamination as specified in Table 6.9., applicable for raw or dilute measurements;
 - (iii) Contamination as specified in Table 6.10., applicable for raw measurements.

Table 6.9.

Contamination limits, applicable for raw or dilute measurements [$\mu\text{mol/mol} = \text{ppm}$ (3,2)]

<i>Constituent</i>	<i>Purified Synthetic Air</i> ^a	<i>Purified N₂</i> ^a
THC (C ₁ equivalent)	$\leq 0,05 \mu\text{mol/mol}$	$\leq 0,05 \mu\text{mol/mol}$
CO	$\leq 1 \mu\text{mol/mol}$	$\leq 1 \mu\text{mol/mol}$
CO ₂	$\leq 1, \mu\text{mol/mol}$	$\leq 10 \mu\text{mol/mol}$
O ₂	0,205 to 0,215 mol/mol	$\leq 2 \mu\text{mol/mol}$
NO _x	$\leq 0,02 \mu\text{mol/mol}$	$\leq 0,02 \mu\text{mol/mol}$

^a It is not required that these levels of purity are internationally and/or nationally recognized standards traceable."

Table 6.10.

Contamination limits applicable for raw measurements [$\mu\text{mol/mol} = \text{ppm}$ (3,2)]

<i>Constituent</i>	<i>Purified Synthetic Air</i> ^a	<i>Purified N₂</i> ^a
THC (C ₁ equivalent)	$\leq 1 \mu\text{mol/mol}$	$\leq 1 \mu\text{mol/mol}$
CO	$\leq 1 \mu\text{mol/mol}$	$\leq 1 \mu\text{mol/mol}$
CO ₂	$\leq 400 \mu\text{mol/mol}$	$\leq 400 \mu\text{mol/mol}$
O ₂	0,18 to 0,21 mol/mol	-
NO _x	$\leq 0,1 \mu\text{mol/mol}$	$\leq 0,1 \mu\text{mol/mol}$

^a It is not required that these levels of purity are international and/or national recognized standards traceable.

(b) The following gases shall be used with a FID analyzer:

- (i) FID fuel shall be used with an H₂ concentration of (0,39 to 0,41) mol/mol, balance He or N₂. The mixture shall not contain more than 0,05 $\mu\text{mol/mol}$ THC;

- (ii) FID burner air shall be used that meets the specifications of purified air in paragraph (a) of this point;
 - (iii) FID zero gas. Flame-ionization detectors shall be zeroed with purified gas that meets the specifications in paragraph (a) of this point, except that the purified gas O₂ concentration may be any value;
 - (iv) FID propane span gas. The THC FID shall be spanned and calibrated with span concentrations of propane, C₃H₈. It shall be calibrated on a carbon number basis of one (C₁);
 - (v) Reserved;
- (c) The following gas mixtures shall be used, with gases traceable within ±1,0 % of the international and/or national recognized standards true value or of other gas standards that are approved:
- (i) Reserved;
 - (ii) Reserved;
 - (iii) C₃H₈, balance purified synthetic air and/or N₂ (as applicable);
 - (iv) CO, balance purified N₂;
 - (v) CO₂, balance purified N₂;
 - (vi) NO, balance purified N₂;
 - (vii) NO₂, balance purified synthetic air;
 - (viii) O₂, balance purified N₂;
 - (ix) C₃H₈, CO, CO₂, NO, balance purified N₂;
 - (x) C₃H₈, CH₄, CO, CO₂, NO, balance purified N₂.
- (d) Gases for species other than those listed in paragraph (c) of this point may be used (such as methanol in air, which may be used to determine response factors), as long as they are traceable to within ± 3,0 % of the international and/or national recognized standards true value, and meet the stability requirements of point 9.5.1.2.;
- (e) Own calibration gases may be generated using a precision blending device, such as a gas divider, to dilute gases with purified N₂ or purified synthetic air. If the gas dividers meet the specifications in point 9.4.5.6., and the gases being blended meet the requirements of paragraphs (a) and (c) of this point, the resulting blends are considered to meet the requirements of this point 9.5.1.1..

9.5.1.2. Concentration and expiration date

The concentration of any calibration gas standard and its expiration date specified by the gas supplier shall be recorded.

- (a) No calibration gas standard may be used after its expiration date, except as allowed by paragraph (b) of this point.
- (b) Calibration gases may be relabelled and used after their expiration date if it is approved in advance by type approval or certification authority.

9.5.1.3. Gas transfer

Gases shall be transferred from their source to analyzers using components that are dedicated to controlling and transferring only those gases.

The shelf life of all calibration gases shall be respected. The expiration date of the calibration gases stated by the manufacturer shall be recorded.

9.5.2. Mass standards

PM balance calibration weights that are certified as international and/or national recognized standards-traceable within 0,1 % uncertainty shall be used. Calibration weights may be certified by any calibration lab that maintains international and/or national recognized standards-traceability. It shall be made sure that the lowest calibration weight has no greater than ten times the mass of an unused PM-sample medium. The calibration report shall also state the density of the weights.

Appendix 1

Particle number emissions measurement equipment

1. Measurement test procedure

1.1. Sampling

Particle number emissions shall be measured by continuous sampling from either a partial flow dilution system, as described in point 9.2.3. of this Annex or a full flow dilution system as described in point 9.2.2. of this Annex.

1.1.1. Diluent filtration

Diluent used for both the primary and, where applicable, secondary dilution of the exhaust gas in the dilution system shall be passed through filters meeting the High-Efficiency Particulate Air (HEPA) filter requirements defined in Article 2(23). The diluent may optionally be charcoal scrubbed before being passed to the HEPA filter to reduce and stabilize the hydrocarbon concentrations in the diluent. It is recommended that an additional coarse particle filter is situated before the HEPA filter and after the charcoal scrubber, if used.

1.2. Compensating for particle number sample flow – full flow dilution systems

To compensate for the mass flow extracted from the dilution system for particle number sampling the extracted mass flow (filtered) shall be returned to the dilution system. Alternatively, the total mass flow in the dilution system may be mathematically corrected for the particle number sample flow extracted. Where the total mass flow extracted from the dilution system for the sum of particle number sampling and particulate mass sampling is less than 0,5 % of the total diluted exhaust gas flow in the dilution tunnel (med) this correction, or flow return, may be neglected.

1.3. Compensating for particle number sample flow – partial flow dilution systems

1.3.1. For partial flow dilution systems the mass flow extracted from the dilution system for particle number sampling shall be accounted for in controlling the proportionality of sampling. This shall be achieved either by feeding the particle number sample flow back into the dilution system upstream of the flow measuring device or by mathematical correction as outlined in point 1.3.2.. In the case of total sampling type partial flow dilution systems, the mass flow extracted for particle number sampling shall also be corrected for in the particulate mass calculation as outlined in point 1.3.3..

1.3.2. The instantaneous exhaust gas flow rate into the dilution system (q_{mp}), used for controlling the proportionality of sampling, shall be corrected according to one of the following methods:

- (a) In the case where the extracted particle number sample flow is discarded, equation (6-20) in point 8.1.8.6.1. of this Annex shall be replaced by equation (6-29):

$$q_{mp} = q_{mdew} - q_{mdw} + q_{ex} \quad (6-29)$$

Where:

- q_{mdew} is the diluted exhaust gas mass flow rate, kg/s,
 q_{mdw} is the dilution air mass flow rate, kg/s,
 q_{ex} is the particle number sample mass flow rate, kg/s.

The q_{ex} signal sent to the partial flow system controller shall be accurate to within $\pm 0,1$ % of q_{mdew} at all times and should be sent with frequency of at least 1 Hz.

- (b) In the case where the extracted particle number sample flow is fully or partially discarded, but an equivalent flow is fed back to the dilution system upstream of the flow measurement device, equation (6-20) in point 8.1.8.6.1. of this Annex shall be replaced by equation (6-30):

$$q_{mp} = q_{mdew} - q_{mdw} + q_{ex} - q_{sw} \quad (6-30)$$

Where:

- q_{mdew} is the diluted exhaust gas mass flow rate, kg/s,
 q_{mdw} is the dilution air mass flow rate, kg/s,
 q_{ex} is the particle number sample mass flow rate, kg/s,
 q_{sw} is the mass flow rate fed back into dilution tunnel to compensate for particle number sample extraction, kg/s.

The difference between q_{ex} and q_{sw} sent to the partial flow system controller shall be accurate to within $\pm 0,1$ % of q_{mdew} at all times. The signal (or signals) should be sent with frequency of at least 1 Hz.

1.3.3. Correction of PM measurement

When a particle number sample flow is extracted from a total sampling partial flow dilution system, the mass of particulates (m_{PM}) calculated in point 2.3.1.1. of Annex VII shall be corrected as follows to account for the flow extracted. This correction is required even where filtered extracted flow is fed back into the partial flow dilution systems, as set out in equation (6-31):

$$m_{PM,corr} = m_{PM} \times \frac{m_{sed}}{(m_{sed} - m_{ex})} \quad (6-31)$$

Where:

- m_{PM} is the mass of particulates determined in accordance with point 2.3.1.1. of Annex VII, g/test,
- m_{sed} is the total mass of diluted exhaust gas passing through the dilution tunnel, kg,
- m_{ex} is the total mass of diluted exhaust gas extracted from the dilution tunnel for particle number sampling, kg.

1.3.4. Proportionality of partial flow dilution sampling

For particle number measurement, exhaust gas mass flow rate, determined according to any of the methods described in points 8.4.1.3. to 8.4.1.7. of this Annex, is used for controlling the partial flow dilution system to take a sample proportional to the exhaust gas mass flow rate. The quality of proportionality shall be checked by applying a regression analysis between sample and exhaust gas flow in accordance with point 8.2.1.2. of this Annex.

1.3.5. Particle number calculation

Determination and calculation of PN are laid down in Appendix 5 of Annex VII.

2. Measurement equipment

2.1. Specification

2.1.1. System overview

2.1.1.1. The particle sampling system shall consist of a probe or sampling point extracting a sample from a homogeneously mixed flow in a dilution system as described in point 9.2.2. or 9.2.3. of this Annex, a volatile particle remover (VPR) upstream of a particle number counter (PNC) and suitable transfer tubing.

2.1.1.2. It is recommended that a particle size pre-classifier (e.g. cyclone, impactor, etc.) be located prior to the inlet of the VPR. However, a sample probe acting as an appropriate size-classification device, such as shown in Figure 6.8., is an acceptable alternative to the use of a particle size pre-classifier. In the case of partial flow dilution systems it is acceptable to use the same pre-classifier for particulate mass and particle number sampling, extracting the particle number sample from the dilution system downstream of the pre-classifier. Alternatively separate pre-classifiers may be used, extracting the particle number sample from the dilution system upstream of the particulate mass pre-classifier.

2.1.2. General requirements

2.1.2.1. The particle sampling point shall be located within a dilution system.

The sampling probe tip or particle sampling point and particle transfer tube (PTT) together comprise the particle transfer system (PTS). The PTS conducts the sample from the dilution tunnel to the entrance of the VPR. The PTS shall meet the following conditions:

In the case of full flow dilution systems and partial flow dilution systems of the fractional sampling type (as described in point 9.2.3. of this Annex) the sampling probe shall be installed near the tunnel centre line, 10 to 20 tunnel diameters downstream of the gas inlet, facing upstream into the tunnel gas flow with its axis at the tip parallel to that of the dilution tunnel. The sampling probe shall be positioned within the dilution tract so that the sample is taken from a homogeneous diluent/exhaust gas mixture.

In the case of partial flow dilution systems of the total sampling type (as described in point 9.2.3. of this Annex) the particle sampling point or sampling probe shall be located in the particulate transfer tube, upstream of the particulate filter holder, flow measurement device and any sample/bypass bifurcation point. The sampling point or sampling probe shall be positioned so that the sample is taken from a homogeneous diluent/exhaust gas mixture. The dimensions of the particle sampling probe should be sized not to interfere with the operation of the partial flow dilution system.

Sample gas drawn through the PTS shall meet the following conditions:

- (a) In the case of full flow dilution systems, it shall have a flow Reynolds number (Re) of < 1700 ;
- (b) In the case of partial flow dilution systems, it shall have a flow Reynolds number (Re) of < 1700 in the PTT i.e. downstream of the sampling probe or point;
- (c) It shall have a residence time in the PTS of ≤ 3 seconds.
- (d) Any other sampling configuration for the PTS for which equivalent particle penetration at 30 nm can be demonstrated will be considered acceptable.
- (e) The outlet tube (OT) conducting the diluted sample from the VPR to the inlet of the PNC shall have the following properties:
- (f) It shall have an internal diameter of ≥ 4 mm;
- (g) Sample Gas flow through the OT shall have a residence time of $\leq 0,8$ second.
- (h) Any other sampling configuration for the OT for which equivalent particle penetration at 30 nm can be demonstrated will be considered acceptable.

2.1.2.2. The VPR shall include devices for sample dilution and for volatile particle removal.

- 2.1.2.3. All parts of the dilution system and the sampling system from the exhaust pipe up to the PNC, which are in contact with raw and diluted exhaust gas, shall be designed to minimize deposition of the particles. All parts shall be made of electrically conductive materials that do not react with exhaust gas components, and shall be electrically grounded to prevent electrostatic effects.
- 2.1.2.4. The particle sampling system shall incorporate good aerosol sampling practice that includes the avoidance of sharp bends and abrupt changes in cross-section, the use of smooth internal surfaces and the minimisation of the length of the sampling line. Gradual changes in the cross-section are permissible.
- 2.1.3. Specific requirements
- 2.1.3.1. The particle sample shall not pass through a pump before passing through the PNC.
- 2.1.3.2. A sample pre-classifier is recommended.
- 2.1.3.3. The sample preconditioning unit shall:
- 2.1.3.3.1. Be capable of diluting the sample in one or more stages to achieve a particle number concentration below the upper threshold of the single particle count mode of the PNC and a gas temperature below 308 K (35 °C) at the inlet to the PNC;
- 2.1.3.3.2. Include an initial heated dilution stage which outputs a sample at a temperature of ≥ 423 K (150 °C) and ≤ 673 K (400 °C), and dilutes by a factor of at least 10;
- 2.1.3.3.3. Control heated stages to constant nominal operating temperatures, within the range specified in point 2.1.4.3.2., to a tolerance of ± 10 °C. Provide an indication of whether or not heated stages are at their correct operating temperatures;
- 2.1.3.3.4. Achieve a particle concentration reduction factor ($f_r(d_i)$), as defined in point 2.2.2.2., for particles of 30 nm and 50 nm electrical mobility diameters, that is no more than 30 % and 20 % respectively higher, and no more than 5 % lower than that for particles of 100 nm electrical mobility diameter for the VPR as a whole;
- 2.1.3.3.5. Also achieve $> 99,0$ % vaporisation of 30 nm tetracontane ($\text{CH}_3(\text{CH}_2)_{38}\text{CH}_3$) particles, with an inlet concentration of ≥ 10000 cm^{-3} , by means of heating and reduction of partial pressures of the tetracontane.
- 2.1.3.4. The PNC shall:
- 2.1.3.4.1. Operate under full flow operating conditions;
- 2.1.3.4.2. Have a counting accuracy of ± 10 % across the range 1 cm^{-3} to the upper threshold of the single particle count mode of the PNC against a traceable standard. At concentrations below 100 cm^{-3} measurements averaged over extended sampling periods may be required to demonstrate the accuracy of the PNC with a high degree of statistical confidence;

- 2.1.3.4.3. Have a readability of at least $0,1 \text{ particle cm}^{-3}$ at concentrations below 100 cm^{-3} ;
- 2.1.3.4.4. Have a linear response to particle concentrations over the full measurement range in single particle count mode;
- 2.1.3.4.5. Have a data reporting frequency equal to or greater than $0,5 \text{ Hz}$;
- 2.1.3.4.6. Have a response time over the measured concentration range of less than 5 s ;
- 2.1.3.4.7. Incorporate a coincidence correction function up to a maximum 10% correction, and may make use of an internal calibration factor as determined in point 2.2.1.3., but shall not make use of any other algorithm to correct for or define the counting efficiency;
- 2.1.3.4.8. Have counting efficiencies at particle sizes of $23 \text{ nm} (\pm 1 \text{ nm})$ and $41 \text{ nm} (\pm 1 \text{ nm})$ electrical mobility diameter of 50% ($\pm 12 \%$) and $> 90 \%$ respectively. These counting efficiencies may be achieved by internal (for example; control of instrument design) or external (for example; size pre-classification) means;
- 2.1.3.4.9. If the PNC makes use of a working liquid, it shall be replaced at the frequency specified by the instrument manufacturer.
- 2.1.3.5. Where they are not held at a known constant level at the point at which PNC flow rate is controlled, the pressure and/or temperature at inlet to the PNC shall be measured and reported for the purposes of correcting particle concentration measurements to standard conditions.
- 2.1.3.6. The sum of the residence time of the PTS, VPR and OT plus the response time of the PNC shall be no greater than 20 s .
- 2.1.3.7. The transformation time of the entire particle number sampling system (PTS, VPR, OT and PNC) shall be determined by aerosol switching directly at the inlet of the PTS. The aerosol switching shall be done in less than $0,1 \text{ s}$. The aerosol used for the test shall cause a concentration change of at least 60% full scale (FS).

The concentration trace shall be recorded. For time alignment of the particle number concentration and exhaust gas flow signals, the transformation time is defined as the time from the change (t_0) until the response is 50% of the final reading (t_{50}).

2.1.4. Recommended system description

This point contains the recommended practice for measurement of particle number. However, any system meeting the performance specifications in points 2.1.2. and 2.1.3. is acceptable.

Figures 6.9. and 6.10. are schematic drawings of the recommended particle sampling system configurations for partial and full flow dilution systems respectively.

Figure 6.9.
Schematic of recommended particle sampling system – Partial flow sampling

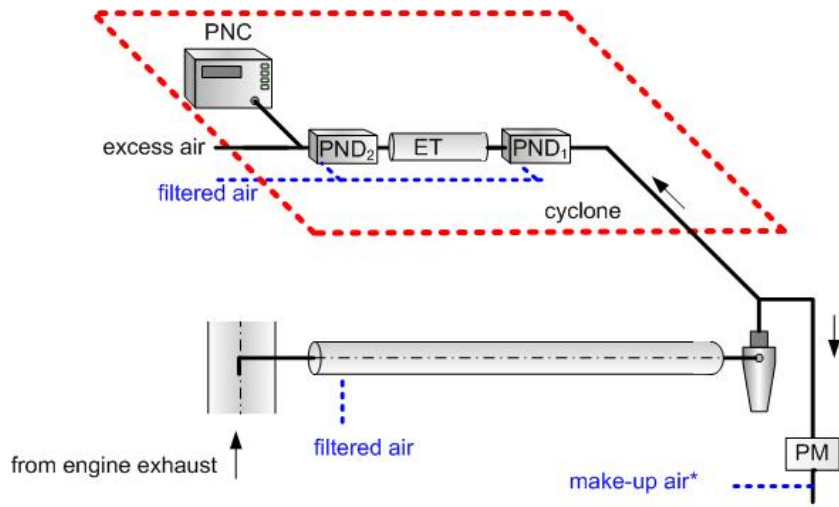

* Alternatively, the control software might account for the flow removed by the PN system

Figure 6.10.

Schematic of recommended particle sampling system – Full flow sampling

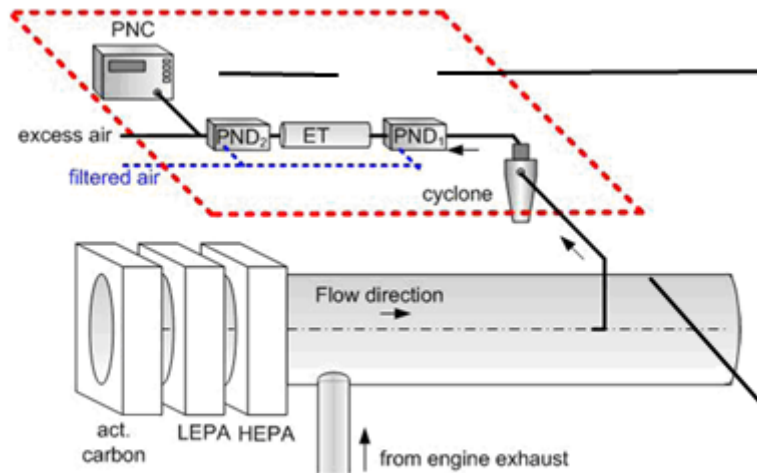

2.1.4.1. Sampling system description

The particle sampling system shall consist of a sampling probe tip or particle sampling point in the dilution system, a particle transfer tube (PTT), a particle pre-classifier (PCF) and a volatile particle remover (VPR) upstream of the particle number concentration measurement (PNC) unit. The VPR shall include devices for sample dilution (particle number diluters: PND₁ and PND₂) and particle evaporation (Evaporation tube, ET). The sampling probe or sampling point for the test gas flow shall be so arranged within the dilution tract that a representative sample gas flow is taken from a homogeneous diluent/exhaust gas mixture. The sum of the residence time of the system plus the response time of the PNC shall be no greater than 20 s.

2.1.4.2. Particle transfer system

The sampling probe tip or particle sampling point and Particle Transfer Tube (PTT) together comprise the Particle Transfer System (PTS). The PTS conducts the sample from the dilution tunnel to the entrance to the first particle number diluter. The PTS shall meet the following conditions:

In the case of full flow dilution systems and partial flow dilution systems of the fractional sampling type (as described in point 9.2.3. of this Annex) the sampling probe shall be installed near the tunnel centre line, 10 to 20 tunnel diameters downstream of the gas inlet, facing upstream into the tunnel gas flow with its axis at the tip parallel to that of the dilution tunnel. The sampling probe shall be positioned within the dilution tract so that the sample is taken from a homogeneous diluent/exhaust gas mixture.

In the case of partial flow dilution systems of the total sampling type (as described in point 9.2.3. of this Annex) the particle sampling point shall be located in the particulate transfer tube, upstream of the particulate filter holder, flow measurement device and any sample/bypass bifurcation point. The sampling point or sampling probe shall be positioned so that the sample is taken from a homogeneous diluent/exhaust gas mixture.

Sample gas drawn through the PTS shall meet the following conditions:

It shall have a flow Reynolds number (Re) of $< 1\,700$;

It shall have a residence time in the PTS of ≤ 3 seconds.

Any other sampling configuration for the PTS for which equivalent particle penetration for particles of 30 nm electrical mobility diameter can be demonstrated will be considered acceptable.

The outlet tube (OT) conducting the diluted sample from the VPR to the inlet of the PNC shall have the following properties:

It shall have an internal diameter of ≥ 4 mm;

Sample gas flow through the POT shall have a residence time of $\leq 0,8$ second.

Any other sampling configuration for the OT for which equivalent particle penetration for particles of 30 nm electrical mobility diameter can be demonstrated will be considered acceptable.

2.1.4.3. Particle pre-classifier

The recommended particle pre-classifier shall be located upstream of the VPR. The pre-classifier 50 % cut point particle diameter shall be between 2,5 μm and 10 μm at the volumetric flow rate selected for sampling particle number emissions. The pre-classifier shall allow at least 99 % of the mass concentration of 1 μm particles entering the pre-classifier to pass through the exit of the pre-classifier at the volumetric flow rate selected for sampling particle number emissions. In the case of partial flow dilution systems, it is acceptable to use the same pre-classifier for particulate mass and particle number sampling, extracting the particle number sample from the dilution system downstream of the pre-classifier. Alternatively separate pre-classifiers may be used, extracting the particle number sample from the dilution system upstream of the particulate mass pre-classifier.

2.1.4.4. Volatile particle remover (VPR)

The VPR shall comprise one particle number diluter (PND₁), an evaporation tube and a second diluter (PND₂) in series. This dilution function is to reduce the number concentration of the sample entering the particle concentration measurement unit to less than the upper threshold of the single particle count mode of the PNC and to suppress

nucleation within the sample. The VPR shall provide an indication of whether or not PND₁ and the evaporation tube are at their correct operating temperatures.

The VPR shall achieve > 99,0 % vaporisation of 30 nm tetracontane (CH₃(CH₂)₃₈CH₃) particles, with an inlet concentration of $\geq 10000 \text{ cm}^{-3}$, by means of heating and reduction of partial pressures of the tetracontane. It shall also achieve a particle concentration reduction factor (f_r) for particles of 30 nm and 50 nm electrical mobility diameters, that is no more than 30 % and 20 % respectively higher, and no more than 5 % lower than that for particles of 100 nm electrical mobility diameter for the VPR as a whole.

2.1.4.4.1. First particle number dilution device (PND₁)

The first particle number dilution device shall be specifically designed to dilute particle number concentration and operate at a (wall) temperature of 423 K to 673 K (150 °C to 400 °C). The wall temperature setpoint should be held at a constant nominal operating temperature, within this range, to a tolerance of $\pm 10 \text{ °C}$ and not exceed the wall temperature of the ET (point 2.1.4.4.2.). The diluter should be supplied with HEPA filtered dilution air and be capable of a dilution factor of 10 to 200 times.

2.1.4.4.2. Evaporation Tube (ET)

The entire length of the ET shall be controlled to a wall temperature greater than or equal to that of the first particle number dilution device and the wall temperature held at a fixed nominal operating temperature between 300 °C and 400 °C, to a tolerance of $\pm 10 \text{ °C}$.

2.1.4.4.3. Second particle number dilution device (PND₂)

PND₂ shall be specifically designed to dilute particle number concentration. The diluter shall be supplied with HEPA filtered dilution air and be capable of maintaining a single dilution factor within a range of 10 to 30 times. The dilution factor of PND₂ shall be selected in the range between 10 and 15 such that particle number concentration downstream of the second diluter is less than the upper threshold of the single particle count mode of the PNC and the gas temperature prior to entry to the PNC is $< 35 \text{ °C}$.

2.1.4.5. Particle number counter (PNC)

The PNC shall meet the requirements of point 2.1.3.4..

2.2. Calibration/Validation of the particle sampling system¹

2.2.1. Calibration of the particle number counter

¹ Example calibration/validation methods are available at:
www.unece.org/es/trans/main/wp29/wp29wgs/wp29grpe/pmpfcp

- 2.2.1.1 The Technical Service shall ensure the existence of a calibration certificate for the PNC demonstrating compliance with a traceable standard within a 12-month period prior to the emissions test.
- 2.2.1.2. The PNC shall also be recalibrated and a new calibration certificate issued following any major maintenance.
- 2.2.1.3. Calibration shall be traceable to a standard calibration method:
- (a) By comparison of the response of the PNC under calibration with that of a calibrated aerosol electrometer when simultaneously sampling electrostatically classified calibration particles; or
 - (b) By comparison of the response of the PNC under calibration with that of a second PNC which has been directly calibrated by the above method.

In the electrometer case, calibration shall be undertaken using at least six standard concentrations spaced as uniformly as possible across the PNC's measurement range. These points will include a nominal zero concentration point produced by attaching HEPA filters of at least class H13 of EN 1822:2008, or equivalent performance, to the inlet of each instrument. With no calibration factor applied to the PNC under calibration, measured concentrations shall be within $\pm 10\%$ of the standard concentration for each concentration used, with the exception of the zero point, otherwise the PNC under calibration shall be rejected. The gradient from a linear regression of the two data sets shall be calculated and recorded. A calibration factor equal to the reciprocal of the gradient shall be applied to the PNC under calibration. Linearity of response is calculated as the square of the Pearson product moment correlation coefficient (R^2) of the two data sets and shall be equal to or greater than 0,97. In calculating both the gradient and R^2 the linear regression shall be forced through the origin (zero concentration on both instruments).

In the reference PNC case, calibration shall be undertaken using at least six standard concentrations across the PNC's measurement range. At least 3 points shall be at concentrations below $1\ 000\ \text{cm}^{-3}$, the remaining concentrations shall be linearly spaced between $1\ 000\ \text{cm}^{-3}$ and the maximum of the PNC's range in single particle count mode. These points will include a nominal zero concentration point produced by attaching HEPA filters of at least class H13 of EN 1822:2008, or equivalent performance, to the inlet of each instrument. With no calibration factor applied to the PNC under calibration, measured concentrations shall be within $\pm 10\%$ of the standard concentration for each concentration, with the exception of the zero point, otherwise the PNC under calibration shall be rejected. The gradient from a linear regression of the two data sets shall be calculated and recorded. A calibration factor equal to the reciprocal of the gradient shall be applied to the PNC under calibration. Linearity of response is calculated as the square of the Pearson product moment correlation coefficient (R^2) of the two data sets and shall be equal to or greater than 0,97. In calculating both the gradient and R^2 the linear regression shall be forced through the origin (zero concentration on both instruments).

2.2.1.4. Calibration shall also include a check, against the requirements in point 2.1.3.4.8., on the PNC's detection efficiency with particles of 23 nm electrical mobility diameter. A check of the counting efficiency with 41 nm particles is not required.

2.2.2. Calibration/Validation of the volatile particle remover

2.2.2.1. Calibration of the VPR's particle concentration reduction factors across its full range of dilution settings, at the instrument's fixed nominal operating temperatures, shall be required when the unit is new and following any major maintenance. The periodic validation requirement for the VPR's particle concentration reduction factor is limited to a check at a single setting, typical of that used for measurement on diesel particulate filter equipped non-road mobile machinery. The Technical Service shall ensure the existence of a calibration or validation certificate for the volatile particle remover within a 6-month period prior to the emissions test. If the volatile particle remover incorporates temperature monitoring alarms a 12 month validation interval shall be permissible.

The VPR shall be characterised for particle concentration reduction factor with solid particles of 30 nm, 50 nm and 100 nm electrical mobility diameter. Particle concentration reduction factors ($f_r(d)$) for particles of 30 nm and 50 nm electrical mobility diameters shall be no more than 30 % and 20 % higher respectively, and no more than 5 % lower than that for particles of 100 nm electrical mobility diameter. For the purposes of validation, the mean particle concentration reduction factor shall be within ± 10 % of the mean particle concentration reduction factor (\bar{f}_r) determined during the primary calibration of the VPR.

2.2.2.2. The test aerosol for these measurements shall be solid particles of 30, 50 and 100 nm electrical mobility diameter and a minimum concentration of 5000 particles cm^{-3} at the VPR inlet. Particle concentrations shall be measured upstream and downstream of the components.

The particle concentration reduction factor at each particle size ($f_r(d_i)$) shall be calculated by means of equation (6-32):

$$f_r(d_i) = \frac{N_{in}(d_i)}{N_{out}(d_i)} \quad (6-32)$$

Where:

- $N_{in}(d_i)$ is the upstream particle number concentration for particles of diameter d_i
 - $N_{out}(d_i)$ is the downstream particle number concentration for particles of diameter d_i
 - d_i is the particle electrical mobility diameter (30, 50 or 100 nm)
- $N_{in}(d_i)$ and $N_{out}(d_i)$ shall be corrected to the same conditions.

The mean particle concentration reduction ($\overline{f_r}$) at a given dilution setting shall be calculated by means of equation (6-33):

$$\overline{f_r} = \frac{f_r(30nm) + f_r(50nm) + f_r(100nm)}{3} \quad (6-33)$$

It is recommended that the VPR is calibrated and validated as a complete unit.

- 2.2.2.3. The Technical Service shall ensure the existence of a validation certificate for the VPR demonstrating effective volatile particle removal efficiency within a 6 month period prior to the emissions test. If the volatile particle remover incorporates temperature monitoring alarms a 12 month validation interval shall be permissible. The VPR shall demonstrate greater than 99,0 % removal of tetracontane ($\text{CH}_3(\text{CH}_2)_{38}\text{CH}_3$) particles of at least 30 nm electrical mobility diameter with an inlet concentration of $\geq 10000 \text{ cm}^{-3}$ when operated at its minimum dilution setting and manufacturers recommended operating temperature.
- 2.2.3. Particle number system check procedures
- 2.2.3.1. Prior to each test, the particle counter shall report a measured concentration of less than $0,5 \text{ particles cm}^{-3}$ when a HEPA filter of at least class H13 of EN 1822:2008, or equivalent performance, is attached to the inlet of the entire particle sampling system (VPR and PNC).
- 2.2.3.2. On a monthly basis, the flow into the particle counter shall report a measured value within 5 % of the particle counter nominal flow rate when checked with a calibrated flow meter.
- 2.2.3.3. Each day, following the application of a HEPA filter of at least class H13 of EN 1822:2008, or equivalent performance, to the inlet of the particle counter, the particle counter shall report a concentration of $\leq 0,2 \text{ cm}^{-3}$. Upon removal of this filter, the particle counter shall show an increase in measured concentration to at least 100 particles cm^{-3} when challenged with ambient air and a return to $\leq 0,2 \text{ cm}^{-3}$ on replacement of the HEPA filter.
- 2.2.3.4. Prior to the start of each test it shall be confirmed that the measurement system indicates that the evaporation tube, where featured in the system, has reached its correct operating temperature.
- 2.2.3.5. Prior to the start of each test it shall be confirmed that the measurement system indicates that the diluter PND_1 has reached its correct operating temperature.

Appendix 2

Installation requirements for equipment and auxiliaries

<i>Number</i>	<i>Equipment and auxiliaries</i>	<i>Fitted for emission test</i>
1	Inlet system Inlet manifold Crankcase emission control system Air flow meter Air filter Inlet silencer	 Yes Yes Yes Yes ^(a) Yes ^(a)
2	Exhaust system Exhaust after-treatment system Exhaust manifold Connecting pipes Silencer Tail pipe Exhaust brake Pressure charging device	 Yes Yes Yes ^(b) Yes ^(b) Yes ^(b) No ^(c) Yes
3	Fuel supply pump	Yes ^(d)
4	Fuel injection equipment Prefilter Filter Pump	 Yes Yes Yes
5	High-pressure pipe Injector Electronic control unit, sensors, etc. Governor/control system Automatic full-load stop for the control rack depending on atmospheric conditions	Yes Yes Yes Yes Yes

6	Liquid-cooling equipment Radiator Fan Fan cowl Water pump Thermostat	No No No Yes ^(e) Yes ^(f)
7	Air cooling Cowl Fan or Blower Temperature-regulating device	No ^(g) No ^(g) No
8	Pressure charging equipment Compressor driven either directly by the engine and/or by the exhaust system Charge air cooler Coolant pump or fan (engine-driven) Coolant flow control device	Yes Yes ^{(g)(h)} No ^(g) Yes
9	Auxiliary test-bed fan	Yes, if necessary
10	Anti-pollution device	Yes
11	Starting equipment	Yes or test bed equipment ⁽ⁱ⁾
12	Lubricating oil pump	Yes
13	Certain auxiliaries whose definition is linked with the operation of the non-road mobile machinery and which may be mounted on the engine shall be removed for the test. The following non-exhaustive list is given as an example: (i) air compressor for brakes (ii) power steering compressor (iii) suspension compressor (iv) air-conditioning system.	No
(a) The complete inlet system shall be fitted as provided for the intended application: (i) where there is a risk of an appreciable effect on the engine power;		

- (ii) when the manufacturer requests that this should be done.

In other cases, an equivalent system may be used and a check should be made to ascertain that the intake pressure does not differ by more than 100 Pa from the upper limit specified by the manufacturer for a clean air filter.

- (b) The complete exhaust system shall be fitted as provided for the intended application:

- (i) where there is a risk of an appreciable effect on the engine power;
- (ii) when the manufacturer requests that this should be done.

In other cases, an equivalent system may be installed provided the pressure measured does not differ by more than 1,000 Pa from the upper limit specified by the manufacturer.

- (c) If an exhaust system brake is incorporated in the engine, the throttle valve shall be fixed in the fully open position.
- (d) The fuel feed pressure may be adjusted, if necessary, to reproduce the pressure existing in the particular engine application (particularly when a "fuel return" system is used).
- (e) The cooling-liquid circulation shall be operated by the engine water pump only. Cooling of the liquid may be produced by an external circuit, such that the pressure loss of this circuit and the pressure at the pump inlet remain substantially the same as those of the engine cooling system.
- (f) The thermostat may be fixed in the fully open position.
- (g) When the cooling fan or blower is fitted for the test, the power absorbed shall be added to the results, except for cooling fans of air cooled engines directly fitted on the crankshaft. The fan or blower power shall be determined at the speeds used for the test either by calculation from standard characteristics or by practical tests.
- (h) Charge air-cooled engines shall be tested with charge air cooling, whether liquid - or air-cooled, but if the manufacturer prefers, a test bench system may replace the air cooler. In either case, the measurement of power at each speed shall be made with the maximum pressure drop and the minimum temperature drop of the engine air across the charge air cooler on the test bench system as those specified by the manufacturer.
- (i) The power for electrical or other starting systems shall be provided from the test bed.

Appendix 3

Verification of torque signal broadcast by electronic control unit

1. Introduction

The purpose of this Appendix is to set out the requirements for verification in the case that the manufacturer intends to use the torque signal broadcast by the electronic control unit (ECU), of engines so equipped, during the conduct of in-service monitoring tests according to Commission Delegated Regulation 2016/BBB on monitoring of emissions of in-service engines.

The basis for the net torque shall be uncorrected net torque delivered by the engine inclusive of the equipment and auxiliaries to be included for an emissions test according to Appendix 2.

2. ECU torque signal

With the engine installed on the test bench for conducting the mapping procedure, means shall be provided to read the torque signal broadcast by the ECU according to the requirements of Appendix 6 of Annex I to Commission Delegated Regulation 2016/BBB on monitoring of emissions of in-service engines.

3. Verification procedure

When conducting the mapping procedure according to section 7.6.2. readings of the torque measured by the dynamometer and torque broadcast by the ECU shall be taken simultaneously at a minimum of three points on the torque curve. At least one of the readings shall be taken at a point on the curve where the torque is no less than 98 % of the maximum value.

The torque broadcast by the ECU shall be accepted without correction if, at each point where measurements were taken, the factor calculated from dividing the torque value from the dynamometer by the torque value from the ECU is not less than 0,93 (i.e a difference of 7 %). In this case it shall be recorded in the type approval certificate that the torque broadcast by the ECU has been verified without correction. Where the factor at one or more test points is less than 0,93 the average correction factor shall be determined from all the points where readings were taken and recorded in the type approval certificate. Where a factor is recorded in the type approval certificate it shall be applied to the torque broadcast by the ECU when conducting in-service monitoring tests according to Commission Delegated Regulation 2016/BBB on monitoring of emissions of in-service engines.

Appendix 4

Procedure for the measurement of ammonia

1. This appendix describes the procedure for measurement of ammonia (NH₃). For non-linear analysers, the use of linearising circuits shall be permitted.
2. Three measurement principles are specified for NH₃ measurement and either principle may be used provided it meets the criteria specified in points 2.1., 2.2. or 2.3., respectively. Gas dryers shall not be permitted for NH₃ measurement.

2.1. Fourier Transform Infrared (hereinafter “FTIR”) analyser

2.1.1. Measurement principle

The FTIR employs the broad waveband infrared spectroscopy principle. It allows simultaneous measurement of exhaust system components whose standardized spectra are available in the instrument. The absorption spectrum (intensity/wavelength) is calculated from the measured interferogram (intensity/time) by means of the Fourier transform method.

2.1.2. Installation and sampling

The FTIR shall be installed in accordance with the instrument manufacturer's instructions. The NH₃ wavelength shall be selected for evaluation. The sample path (sampling line, pre-filter(s) and valves) shall be made of stainless steel or PTFE and shall be heated to set points between 383 K (110 °C) and 464 K (191 °C) in order to minimize NH₃ losses and sampling artefacts. In addition, the sampling line shall be as short as practically possible.

2.1.3. Cross interference

The spectral resolution of the NH₃ wavelength shall be within 0,5 cm⁻¹ in order to minimize cross interference from other gases present in the exhaust gas.

2.2. Non Dispersive Ultra Violet Resonance Absorption analyser (hereinafter “NDUV”)

2.2.1. Measurement Principle

The NDUV is based on a purely physical principle, no auxiliary gases or equipment is necessary. The main element of the photometer is an electrode-less discharge lamp. It produces a sharply structured radiation in the ultraviolet range, enabling the measurement of several components such as NH₃.

The photometric system has a dual beam in time design set up to produce a measuring and a reference beam by filter correlation technique.

In order to achieve a high stability of the measuring signal the dual beam in time design is combined with a dual beam in space design. The detector signals processing fosters an almost negligible amount of zero point drift rate.

In the calibration mode of the analyser a sealed-off quartz cell is tilted into the beam path to obtain an exact calibration value, since any reflection and absorption losses of the cell windows are compensated. Since the gas filling of the cell is very stable, this calibration method leads to a very high long term stability of the photometer.

2.2.2. Installation

The analyser shall be installed within an analyser cabinet using extractive sampling in accordance with the instrument manufacturer's instructions. The analyzer location shall be capable of supporting the weight specified by the manufacturer.

The sample path (sampling line, pre-filter(s) and valves) shall be made of stainless steel or PTFE and shall be heated to set points between 383 K (110 °C) and 464 K (191 °C).

In addition, the sampling line shall be as short as possible. Influence from exhaust gas temperature and pressure, installation environment and vibrations on the measurement shall be minimized.

The gas analyzer shall be protected from cold, heat, temperature variations, and strong air currents, accumulation of dust, corrosive atmosphere and vibrations. Adequate air circulation shall be provided to avoid heat build-up. The complete surface shall be used to dissipate the heat losses.

2.2.3. Cross Sensitivity

An appropriate spectral range shall be chosen in order to minimize cross interferences of accompanying gases. Typical components causing cross sensitivities on the NH₃ measurement are SO₂, NO₂ and NO.

Additionally, further methods can be applied to reduce the cross sensitivities.

- (a) Usage of interference filters;
- (b) Cross sensitivity compensation by measuring cross sensitivity components and using the measurement signal for compensation.

2.3. Laser Infrared analyser

2.3.1. Measurement principle

An infrared laser such as a tunable diode laser (TDL) or a quantum cascade laser (QCL) can emit coherent light in the near-infrared region or in mid-infrared region respectively

where nitrogen compounds including NH_3 have strong absorption. This laser optics can give a pulsed-mode high resolution narrow band near-infrared or mid-infrared spectrum. Therefore, laser infrared analyzers can reduce interference caused by the spectral overlap of co-existing components in engine exhaust gas.

2.3.2. Installation

The analyser shall be installed either directly in the exhaust pipe (in-situ) or within an analyser cabinet using extractive sampling in accordance with the instrument manufacturers instructions. If installed in an analyser cabinet, the sample path (sampling line, pre-filter(s) and valves) shall be made of stainless steel or PTFE and shall be heated to set points between 383 K (110 °C) and 464 K (191 °C) in order to minimize NH_3 losses and sampling artefacts. In addition, the sampling line shall be as short as practically possible.

Influence from exhaust gas temperature and pressure, installation environment and vibrations on the measurement shall be minimized, or compensation techniques be used.

If applicable, sheath air used in conjunction with in-situ measurement for protection of the instrument, shall not affect the concentration of any exhaust gas component measured downstream of the device, or sampling of other exhaust gas components shall be made upstream of the device.

2.3.3. Interference verification for NH_3 laser infrared analyzers (cross interference)

2.3.3.1. Scope and frequency

If NH_3 is measured using laser infrared analyser, the amount of interference shall be verified after initial analyser installation and after major maintenance.

2.3.3.2. Measurement principles for interference verification

Interference gasses can positively interfere with certain laser infrared analyzer by causing a response similar to NH_3 . If the analyzer uses compensation algorithms that utilize measurements of other gases to meet this interference verification, these other measurements shall be simultaneously conducted to test the compensation algorithms during the analyzer interference verification.

Good engineering judgment shall be used to determine interference gases for laser infrared analyzer. Note that interference species, with the exception of H_2O , are dependent on the NH_3 infrared absorption band chosen by the instrument manufacturer. For each analyzer the NH_3 infrared absorption band shall be determined. For each NH_3 infrared absorption band, good engineering judgment shall be used to determine interference gases to use in the verification.

3. Emissions test procedure

3.1. Checking the analysers

Prior to the emissions test, the analyser range shall be selected. Emission analysers with automatic or manual range switching shall be permitted. During the test cycle, the range of the analysers shall not be switched.

Zero and span response shall be determined, if the provisions set out in point 3.4.2. do not apply for the instrument. For the span response, a NH₃ gas that meets the specifications set out in point 4.2.7., shall be used. The use of reference cells that contain NH₃ span gas is permitted.

3.2. Collection of emission relevant data

At the start of the test sequence, the NH₃ data collection shall be started, simultaneously. The NH₃ concentration shall be measured continuously and stored with at least 1 Hz on a computer system.

3.3. Operations after test

At the completion of the test, sampling shall continue until system response times have elapsed. Determination of analyser's drift in accordance with point 3.4.1. shall only be required if the information required in point 3.4.2. is not available.

3.4. Analyser drift

3.4.1. As soon as practical but no later than 30 minutes after the test cycle is complete or during the soak period, the zero and span responses of the analyser shall be determined. The difference between the pre-test and post-test results shall be less than 2 %t of full scale.

3.4.2. Determination of analyser drift is not required in the following situations:

- (a) If the zero and span drift specified by the instrument manufacturer in points 4.2.3. and 4.2.4. meets the requirements of point 3.4.1.;
- (b) The time interval for zero and span drift specified by the instrument manufacturer in points 4.2.3. and 4.2.4. exceeds the duration of the test.

4. Analyser specification and verification

4.1. Linearity requirements

The analyser shall comply with the linearity requirements specified in Table 6.5. of this Annex. The linearity verification in accordance with point 8.1.4. of this Annex shall be performed at least at the minimum frequency set out in Table 6.4. of this Annex. With the prior approval of the approval authority, less than 10 reference points are permitted, if an equivalent accuracy can be demonstrated.

For the linearity verification, a NH₃ gas that meets the specifications set out in point 4.2.7. shall be used. The use of reference cells that contain NH₃ span gas shall be permitted.

Instruments, whose signals are used for compensation algorithms, shall meet the linearity requirements specified in Table 6.5. of this Annex. Linearity verification shall be done as required by internal audit procedures, by the instrument manufacturer or in accordance with ISO 9000 requirements.

4.2. Analyser specifications

The analyser shall have a measuring range and response time appropriate for the accuracy required to measure the concentration of NH₃ under transient and steady state conditions.

4.2.1. Minimum detection limit

The analyser shall have a minimum detection limit of < 2 ppm under all conditions of testing.

4.2.2. Accuracy

The accuracy, defined as the deviation of the analyser reading from the reference value, shall not exceed $\pm 3\%$ of the reading or ± 2 ppm, whichever is larger.

4.2.3. Zero drift

The drift of the zero response and the related time interval shall be specified by the instrument manufacturer.

4.2.4. Span drift

The drift of the span response and the related time interval shall be specified by the instrument manufacturer.

4.2.5. System response time

The system response time shall be ≤ 20 s.

4.2.6. Rise time

The rise time of the analyser shall be ≤ 5 s.

4.2.7. NH₃ calibration gas

A gas mixture with the following chemical composition shall be available.

NH₃ and purified nitrogen.

The true concentration of the calibration gas shall be within $\pm 3\%$ of the nominal value. The concentration of NH_3 shall be given on a volume basis (volume per cent or volume ppm).

The expiration date of the calibration gases stated by the manufacturer shall be recorded.

4.2.8. Interference verification procedure

The interference verification shall be performed as follows:

- (a) The NH_3 analyzer shall be started, operated, zeroed, and spanned as it would be before an emission test;
- (b) A humidified interference test gas shall be created by bubbling a multi component span gas through distilled H_2O in a sealed vessel. If the sample is not passed through a sample dryer, the vessel temperature shall be controlled to generate an H_2O level at least as high as the maximum expected during emission testing. Interference span gas concentrations shall be used at least as high as the maximum expected during testing;
- (c) The humidified interference test gas shall be introduced into the sample system.
- (d) The water mole fraction, $x_{\text{H}_2\text{O}}$, of the humidified interference test gas shall be measured, as close as possible to the inlet of the analyzer. For example, dew point, T_{dew} , and absolute pressure, p_{total} , shall be measured to calculate $x_{\text{H}_2\text{O}}$;
- (e) Good engineering judgment shall be used to prevent condensation in the transfer lines, fittings, or valves from the point where $x_{\text{H}_2\text{O}}$ is measured to the analyzer;
- (f) Time shall be allowed for the analyser response to stabilize;
- (g) While the analyser measures the sample's concentration, its output shall be recorded for 30 s. The arithmetic mean of this data shall be calculated;
- (h) The analyzer meets the interference verification if the result of paragraph (g) of this point meets the tolerance in this section.
- (i) Interference procedures for individual interference gases may also run separately. If the interference gas levels used are higher than the maximum levels expected during testing, each observed interference value may be scaled down by multiplying the observed interference by the ratio of the maximum expected concentration value to the actual value used during this procedure. Separate interference concentrations of H_2O (down to 0,025 mol/mol H_2O content) that are lower than the maximum levels expected during testing may be run, but the observed H_2O interference shall be scaled up by multiplying the observed interference by the ratio of the maximum expected H_2O concentration value to the actual value used during this procedure. The sum of the scaled interference values

must meet the tolerance for combined interference as specified in paragraph (j) of this point.

- (j) Analyzer shall have combined interference within ± 2 % of the flow-weighted mean concentration of NH_3 expected at the emission limit.

5. Alternative systems

Other systems or analysers may be approved by the approval authority, if it is found that they yield equivalent results in accordance with point 5.1.1. of this Annex. In this case, "Results" in that point shall refer to mean NH_3 concentration calculated for the applicable cycle.

Appendix 5

Description of system responses

1. This appendix describes the times used to express the response of analytical systems and other measurement systems to an input signal.
2. The following times apply, as shown in figure 6-11:
 - 2.1. Delay time is the difference in time between the change of the component to be measured at the reference point and a system response of 10 % of the final reading (t_{10}) with the sampling probe being defined as the reference point.
 - 2.2. Response time is the difference in time between the change of the component to be measured at the reference point and a system response of 90 % of the final reading (t_{90}) with the sampling probe being defined as the reference point.
 - 2.3. Rise time is the difference in time the 10 % and 90 % response of the final reading ($t_{90} - t_{10}$)
 - 2.4. Transformation time is the difference in time between the change of the component to be measured at the reference point and a system response of 50 % of the final reading (t_{50}) with the sampling probe being defined as the reference point

Figure 6-11

Illustration of system responses

